



YAMAHA

PARTS CATALOGUE

(ELECTRIC START)

XT600E'92 (3TB5)
EUROPE

XT600E'92 (3UX3)
SWITZERLAND

XT600ED (3WR3)
OCEANIA (COLOR: FARAWAY BLUE ONLY)

2008/5/21

NEWS No.	DATE	COMMENT
PE0-MC-070058	Jun., 6, 2007	FIG.17: FRAME ILLUSTRATION CORRECTION

123TB-300E1



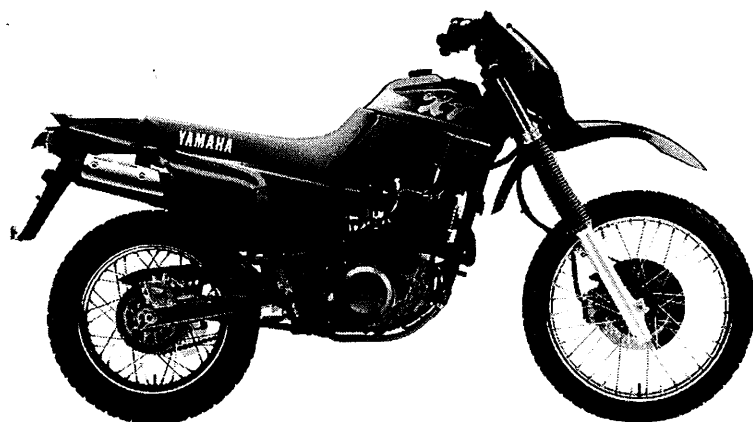

A3



FOREWORD

This Parts Catalogue is related to the parts in use for the Yamaha XT600E'92 (3TB5/3UX3) and XT600ED (3WR3).

When you are ordering replacement parts for the XT600E'92 (3TB5/3UX3) and XT600ED (3WR3), refer to this Parts Catalogue and quote both part numbers and part names correctly.

1. Modifications or additions which have been made after issue of the Parts Catalogue will be announced in the Yamaha Parts News.

It is advisable that according to the Yamaha Parts News you make necessary corrections to the Parts Catalogue on hand to keep it up-to-date.

2. Abbreviations

The following abbreviations are used in this Parts Catalogue.

- U.R. Use size (thickness) and /or number as required.
- U.N. Use as many as you need.
- A.P. Alternate Parts
- L.M. Local Made
- F# Frame No. (Applicable machine No.)

3. The parts marked with (*) in the parts number column of this Catalogue are not supplied with by Yamaha, those have to be found locally.

4. Parts, which are to be supplied in the form of assemblies, are listed with an indention of one letter's space, and a dot (.) is put against the name of each part.

EXAMPLE CARBURETOR ASS'Y
 .JET, pilot
 .NOZZLE, main

5. Indication of No. of constituent parts for assembly

The numeral appearing to the right of each constituent part under the description indicates the quantity of such parts for each individual assembly unit.

EXAMPLE

Part No.	Description	Q'ty	Remarks
2F5-83310-60	FRONT FLASHER LIGHT ASS'Y	2	
115-83311-60	.BULB (6V-18W)	1	
1M1-83309-60	.REFLECTOR	1	

6. Initial Serial No. and Color Code

3TB5	(A) Frame Serial No.	3TB-058101 and following
	(B) Engine Serial No.	3TB-058101 and following

3UX3	(A) Frame Serial No.	3UX-003101 and following
	(B) Engine Serial No.	3UX-003101 and following

3WR3	(A) Frame Serial No.	3WR-003101 and following
	(B) Engine Serial No.	3WR-003101 and following

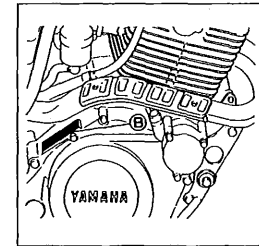
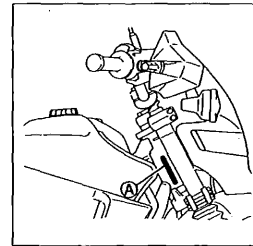

Color Code	Color Name	Abbreviate
NJ	FARAWAY BLUE	FWB
206	PURPLISH WHITE SOLID 1 (NON-OCEANIA)	PWS 1
33	YAMAHA BLACK (NON-OCEANIA)	YB

7. Applicable colors of graphics are represented in the "Remarks" column by the letter(s) appropriately picked out of the full word(s) showing such colors.

EXAMPLE

Part No.	Description	Q'ty	Remarks
2N4-24110-00-X5	FUEL TANK COMP.	1	MAXIM RED
3J1-24240-10	.GRAPHIC, fuel tank set	1	for MXR

CONTENTS

GENERAL SPEC.

ENGINE

Fig. 1	CYLINDER HEAD	1
Fig. 2	CYLINDER	3
Fig. 3	CRANKSHAFT · PISTON	4
Fig. 4	VALVE	6
Fig. 5	CAMSHAFT CHAIN	7
Fig. 6	OIL PUMP	8
Fig. 7	INTAKE	10
Fig. 8	CARBURETOR	12
Fig. 9	EXHAUST	14
Fig. 10	CRANKCASE	15
Fig. 11	CRANKCASE COVER	16
Fig. 12	STARTER CLUTCH	18
Fig. 13	CLUTCH	19
Fig. 14	TRANSMISSION	21
Fig. 15	SHIFT CAM · FORK	23
Fig. 16	SHIFT SHAFT	24

CHASSIS

Fig. 17	FRAME	25
Fig. 18	FENDER	27
Fig. 19	SIDE COVER	29
Fig. 20	REAR ARM	30
Fig. 21	REAR SUSPENSION	32
Fig. 22	STEERING	33

Fig. 23	FRONT FORK	34
Fig. 24	FUEL TANK	36
Fig. 25	SEAT	38
Fig. 26	FRONT WHEEL	39
Fig. 27	REAR WHEEL	41
Fig. 28	REAR BRAKE CALIPER	43
Fig. 29	STEERING HANDLE · CABLE ...	44
Fig. 30	FRONT MASTER CYLINDER ...	45
Fig. 31	STAND · FOOTREST	46
Fig. 32	REAR MASTER CYLINDER	47
Fig. 33	COWLING	49
Fig. 34	GENERATOR	50
Fig. 35	FLASHER LIGHT	51
Fig. 36	METER	52
Fig. 37	HEADLIGHT	53
Fig. 38	TAILLIGHT	54
Fig. 39	HANDLE SWITCH · LEVER	55
Fig. 40	ELECTRICAL 1	56
Fig. 41	ELECTRICAL 2	57

INDIVIDUAL SPEC.

FOR DENMARK, FINLAND, NORWAY, SWEDEN

Fig. 42	ALTERNATE (FENDER)	62
---------	--------------------------	----

FOR ENGLAND, OCEANIA

Fig. 43	ALTERNATE (ELECTRICAL)	64
---------	------------------------------	----

FOR SWITZERLAND

Fig. 44	ALTERNATE (ENGINE)	66
Fig. 45	ALTERNATE (CHASSIS)	67

INDEX (GENERAL SPEC.)

NUMERICAL INDEX

INDEX (INDIVIDUAL SPEC.)

NUMERICAL INDEX

GENERAL SPEC.



FIG. 1 CYLINDER HEAD

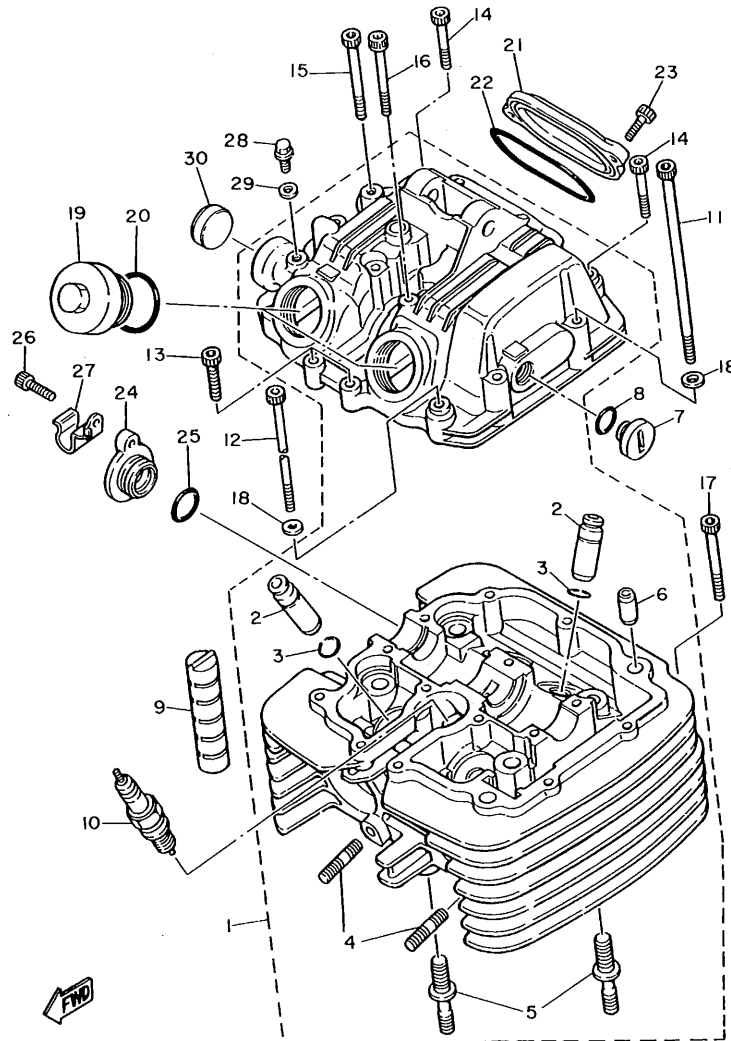

3TB351-0010

REF. NO.	PART NO.	DESCRIPTION	Q'TY	REMARKS
1	3TB-11101-00	CYLINDER HEAD ASSY	1	
2	4H7-11133-10	.GUIDE, intake valve	4	
3	93440-12052	.CIRCLIP	4	
4	90116-06475	.BOLT, stud	4	
5	90116-10378	.BOLT, stud	2	
6	99510-10114	.PIN, dowel	2	
7	90340-14068	PLUG, straight screw	1	
8	93210-13657	O-RING	1	
9	583-11127-00	ABSORBER 3	2	
10	94701-00241	PLUG, spark (NGK DPR8EA-9)	1	
11	91316-06125	BOLT	2	
12	91316-06115	BOLT	1	
13	91316-06025	BOLT	4	
14	91316-06040	BOLT	2	
15	91316-06055	BOLT	6	
16	90109-063E9	BOLT	1	
17	91316-06050	BOLT	1	
18	92906-06600	WASHER, plate	3	
19	1L9-11186-00	COVER, cylinder head side 2	2	
20	93210-32172	O-RING	2	
21	5Y1-11187-00	COVER, cylinder head side 3	1	
22	93210-62446	O-RING	1	
23	91316-06018	BOLT	2	
24	3TB-12215-00	CAP, tensioner case	1	
25	93210-19522	O-RING	1	
26	91316-06020	BOLT	1	
27	90462-15196	CLAMP	1	
28	90109-06418	BOLT	1	

FIG. 1 CYLINDER HEAD

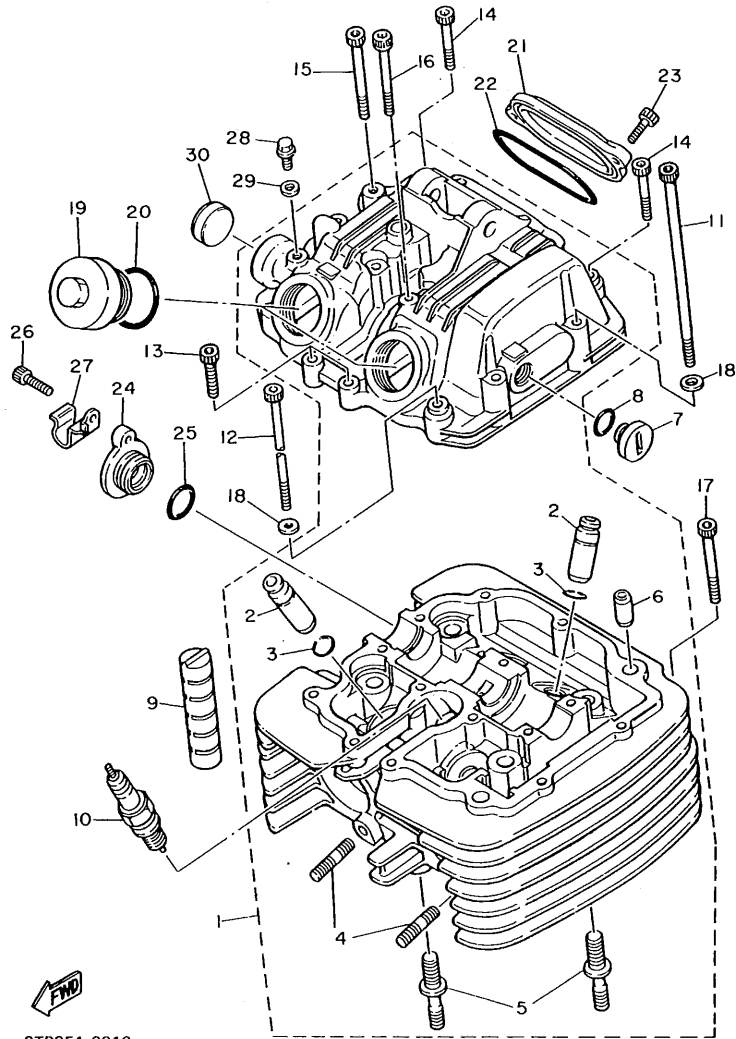

REF. NO.	PART NO.	DESCRIPTION	Q'TY	REMARKS
29	90430-06014	GASKET	1	
30	90338-22207	PLUG	1	

3TB351-0010

B3

FIG. 2 CYLINDER

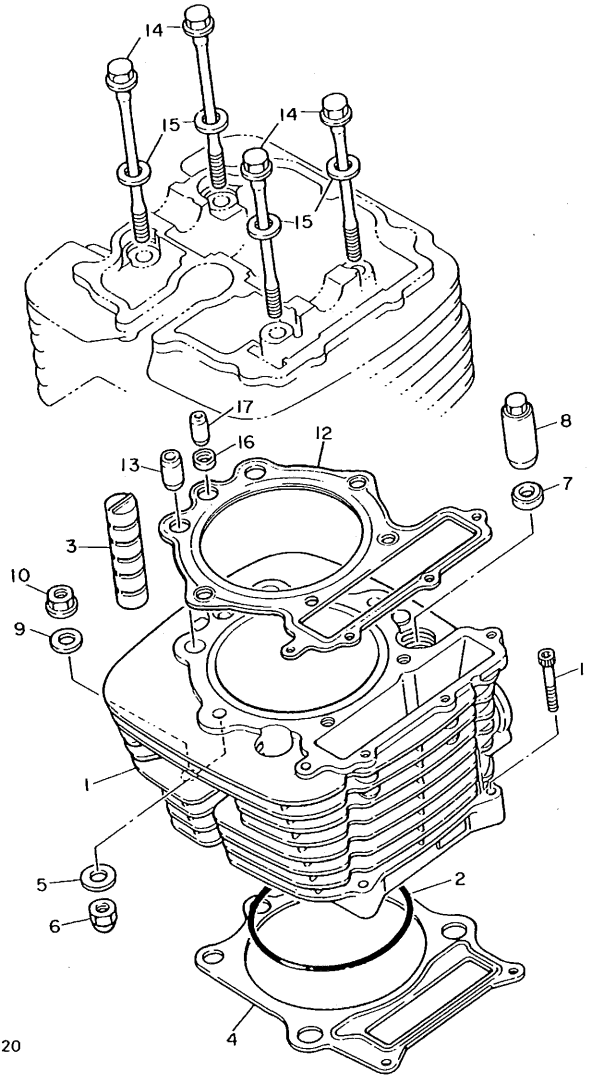

REF. NO.	PART NO.	DESCRIPTION	QTY	REMARKS
1	3TB-11310-00	CYLINDER	1	
2	93210-97524	O-RING	1	
3	583-11127-00	ABSORBER 3	2	
4	1VJ-11351-00	GASKET, cylinder	1	
5	90201-080L8	WASHER, plate	2	
6	90176-08026	NUT, crown	2	
7	90201-10590	WASHER, plate	2	
8	90179-10201	NUT	2	
9	90201-10124	WASHER, plate	2	
10	90179-10279	NUT	2	
11	91316-06035	BOLT	2	
12	2KF-11181-01	GASKET, cylinder head 1	1	
13	91810-05018	PIN, dowel	2	
14	90105-08505	BOLT, washer based	4	
15	90201-085L3	WASHER, plate	4	
16	90430-08178	GASKET	1	
17	99510-08016	PIN, dowel	1	

2TY280-8020

B4

FIG. 3 CRANKSHAFT, PISTON

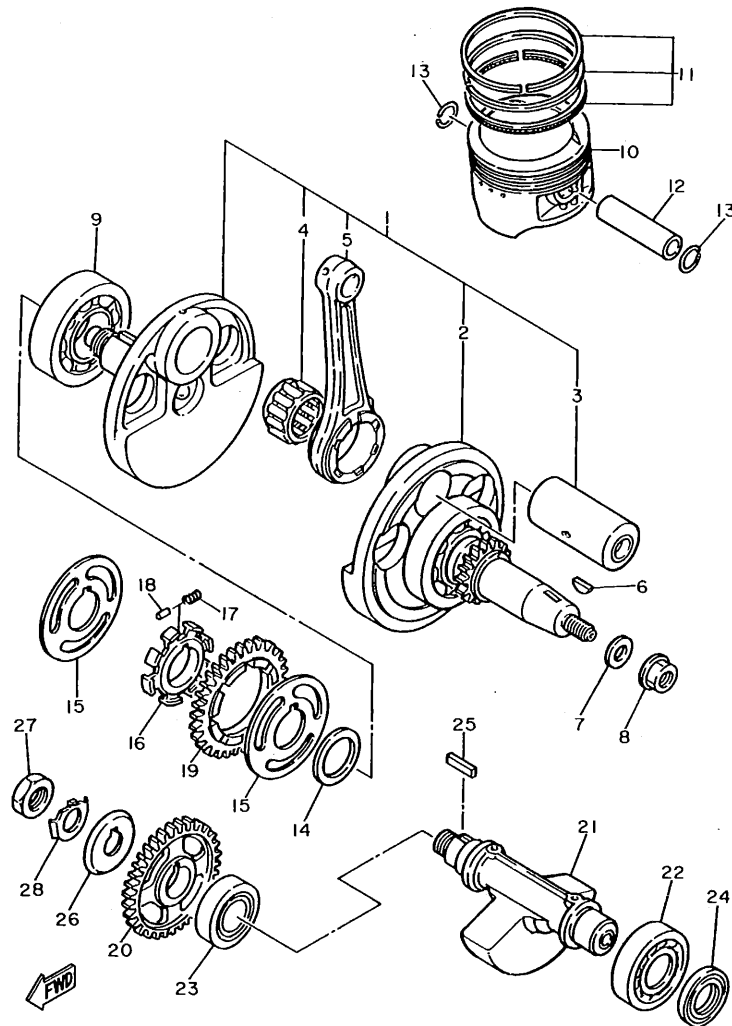

REF. NO.	PART NO.	DESCRIPTION	Q'TY	REMARKS
1	3TB-11400-00	CRANKSHAFT ASSY	1	
2	1VJ-W1141-00	CRANK 1	1	
3	1VJ-11681-00	PIN, crank 1	1	
4	93310-635C6	BEARING, cylindrical	1	
5	3TB-11651-00	ROD, connecting	1	
6	90280-16053	KEY, woodruff	1	
7	90201-140A6	WASHER, plate	1	
8	90179-14317	NUT	1	
9	93306-30702	BEARING (B6307)	1	
10	3TB-11631-00-Y0	PISTON (STD)	1	
	3TB-11636-00	PISTON (0.50MM O/S)	1	AP
	3TB-11638-00	PISTON (1.00MM O/S)	1	AP
11	34L-11610-00	PISTON RING SET (STD)	1	
	34L-11610-20	PISTON RING SET (0.50MM O/S)	1	AP
	34L-11610-40	PISTON RING SET (1.00MM O/S)	1	AP
12	1JK-11633-01	PIN, piston	1	
13	93450-24028	CIRCLIP	2	
14	90201-301F4	WASHER, plate	1	
15	34K-11565-02	WASHER, bearing cover	2	
16	5Y1-11496-01	BOSS, buffer	1	
17	90501-22721	SPRING, compression	8	
18	93605-10090	PIN, dowel	4	
19	2JT-11536-00	GEAR, drive	1	
20	5Y1-11531-00	GEAR, blance wt 44t	1	
21	34K-11454-00	WEIGHT 1	1	
22	93306-30525	BEARING (B6305)	1	
23	93306-30541	BEARING	1	
24	93101-25106	OIL SEAL	1	

FIG. 3 CRANKSHAFT • PISTON

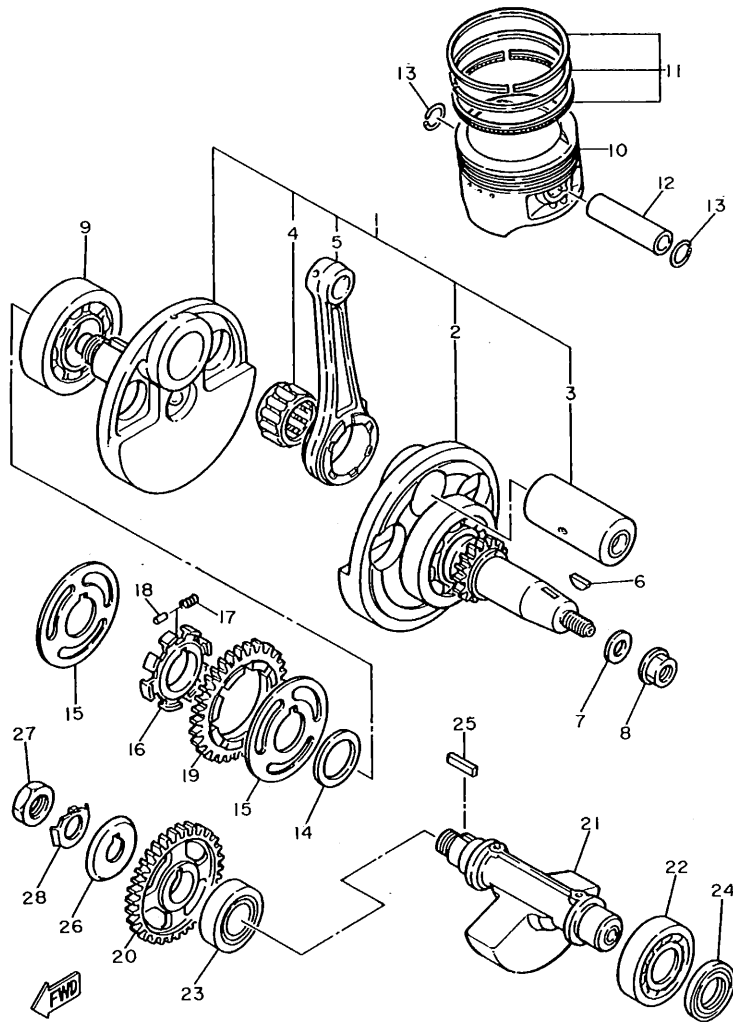

3TB351-0030

REF. NO.	PART NO.	DESCRIPTION	Q'TY	REMARKS
25	90282-05013	KEY, straight	1	
26	34K-11145-00	PLATE, breather 2	1	
27	90170-16343	NUT	1	
28	90215-16242	WASHER, lock	1	

B6

FIG. 4 VALVE

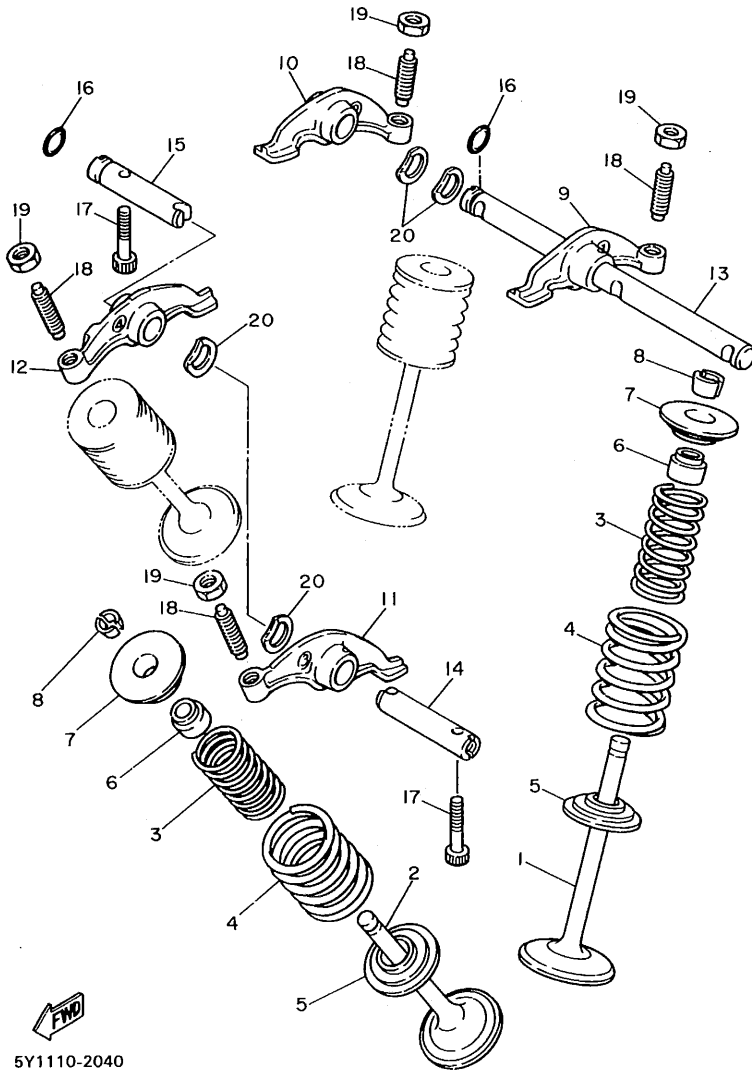

REF. NO.	PART NO.	DESCRIPTION	Q'TY	REMARKS
1	1VJ-12111-00	VALVE, intake	2	
2	1VJ-12121-00	VALVE, exhaust	2	
3	5Y1-12113-00	SPRING, valve inner	4	
4	5Y1-12114-00	SPRING, valve outer	4	
5	4H7-12116-00	SEAT, valve spring	4	
6	1J7-12119-01	SEAL, valve stem	4	
7	2F3-12117-00	RETAINER, valve spring	4	
8	1J7-12118-00	COTTER, valve	8	
9	34K-12151-00	ARM, valve rocker	1	
10	34K-12161-00	ARM, valve rocker 2	1	
11	34K-12162-00	ARM, valve rocker 3	1	
12	34K-12163-00	ARM, valve rocker 4	1	
13	2NX-12146-00	SHAFT, rocker	1	
14	2NX-12156-00	SHAFT, rocker 2	1	
15	2NX-12166-00	SHAFT, rocker 3	1	
16	93210-08521	O-RING	2	
17	90109-063E8	BOLT	2	
18	2NX-12159-00	SCREW, valve adjusting	4	
19	90170-06128	NUT	4	
20	90206-12075	WASHER, wave	4	

5Y1110-2040

B7

FIG. 5 CAMSHAFT • CHAIN

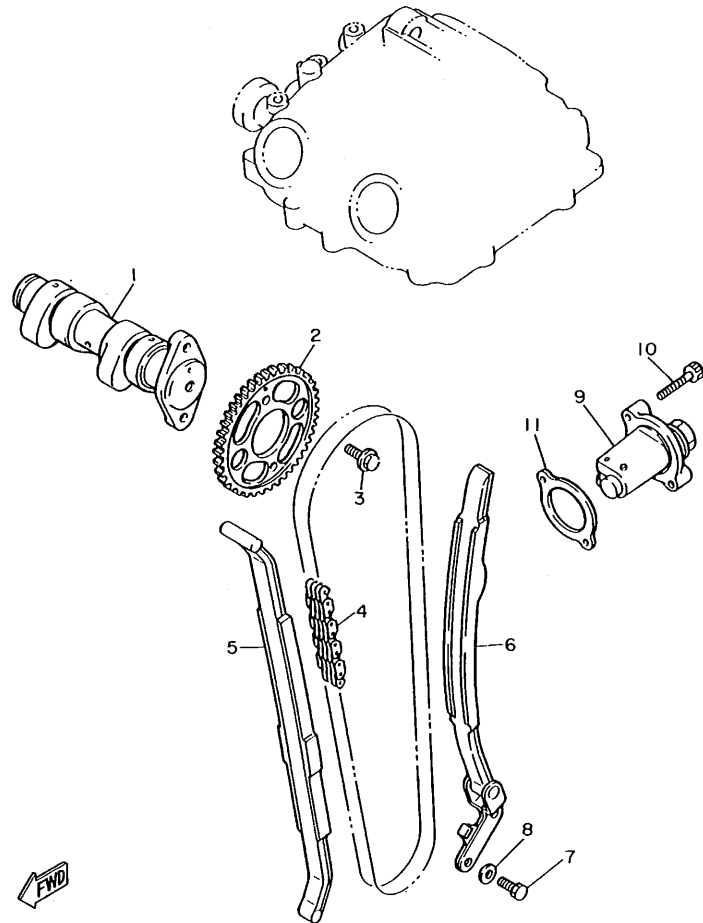

REF. NO.	PART NO.	DESCRIPTION	Q'TY	REMARKS
1	1JK-12171-00	CAMSHAFT 1	1	
2	3TB-12176-00	SPROCKET, cam chain	1	
3	90105-07087	BOLT, washer based	2	
4	94590-27126	CHAIN	1	
5	34K-12231-00	GUIDE, stopper 1	1	
6	34K-12241-00	GUIDE, stopper 2	1	
7	97021-06016	BOLT	2	
8	92901-06600	WASHER, plate	2	
9	3TB-12210-00	TENSIONER ASSY, cam chain	1	
10	91316-06025	BOLT	2	
11	4DW-12213-00	GASKET, tensioner case	1	

3AJ1351-8050

FIG. 6 OIL PUMP

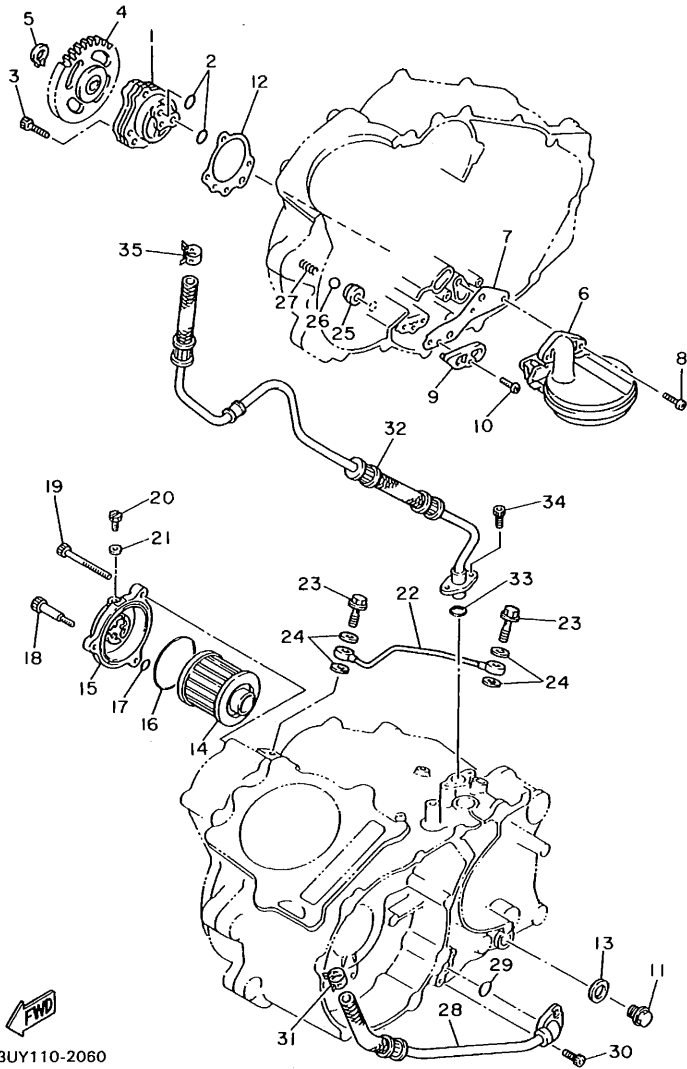

3UY110-2060

REF. NO.	PART NO.	DESCRIPTION	Q'TY	REMARKS
1	3AJ-13300-01	OIL PUMP ASSY	1	
2	93210-13361	O-RING	2	
3	91316-06035	BOLT	3	
4	3AJ-13325-00	GEAR, pump driven	1	
5	99009-11400	CIRCLIP	1	
6	5Y1-W1343-00	STRAINER COMP.	1	
7	4DW-13415-00	SEAL, oil strainer	1	
8	98501-06016	SCREW, pan head	2	
9	5Y1-15427-01	COVER, cap 2	1	
10	98501-06016	SCREW, pan head	1	
11	90340-14132	PLUG	1	
12	3SX-13329-00	GASKET, oil pump	1	
13	214-11198-01	GASKET	1	
14	4X7-13440-90	ELEMENT ASSY, oil cleaner	1	
15	2WK-13447-00	COVER, oil element	1	
16	93210-64297	O-RING	1	
17	93210-07135	O-RING	1	
18	90109-06419	BOLT	1	
19	91316-06080	BOLT	2	
20	90149-05110	SCREW	1	
21	90430-05126	GASKET	1	
22	3AJ-13161-00	PIPE, delivery 1	1	
23	90401-08133	BOLT, union	2	
24	90430-08204	GASKET	4	
25	583-13113-00	SEAT, check ball	1	
26	93503-08007	BALL	1	
27	90501-043E0	SPRING, compression	1	
28	3TB-13464-00	HOSE, oil 1	1	

B9

FIG. 6 OIL PUMP

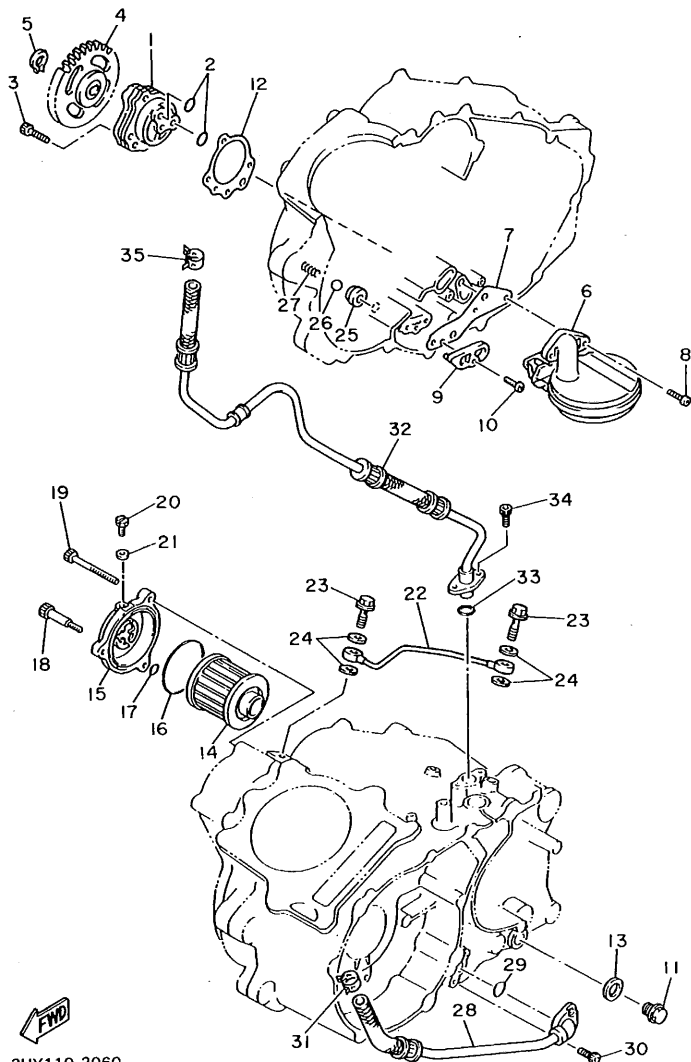

3UY110-2060

REF. NO.	PART NO.	DESCRIPTION	Q'TY	REMARKS
29	93210-10197	O-RING	1	
30	91316-06016	BOLT	2	
31	90450-22052	HOSE CLAMP ASSY	1	
32	3TB-13465-00	HOSE, oil 2	1	
33	93210-15171	O-RING	1	
34	91316-06016	BOLT	2	
35	90450-22052	HOSE CLAMP ASSY	1	

B10

FIG. 7 INTAKE

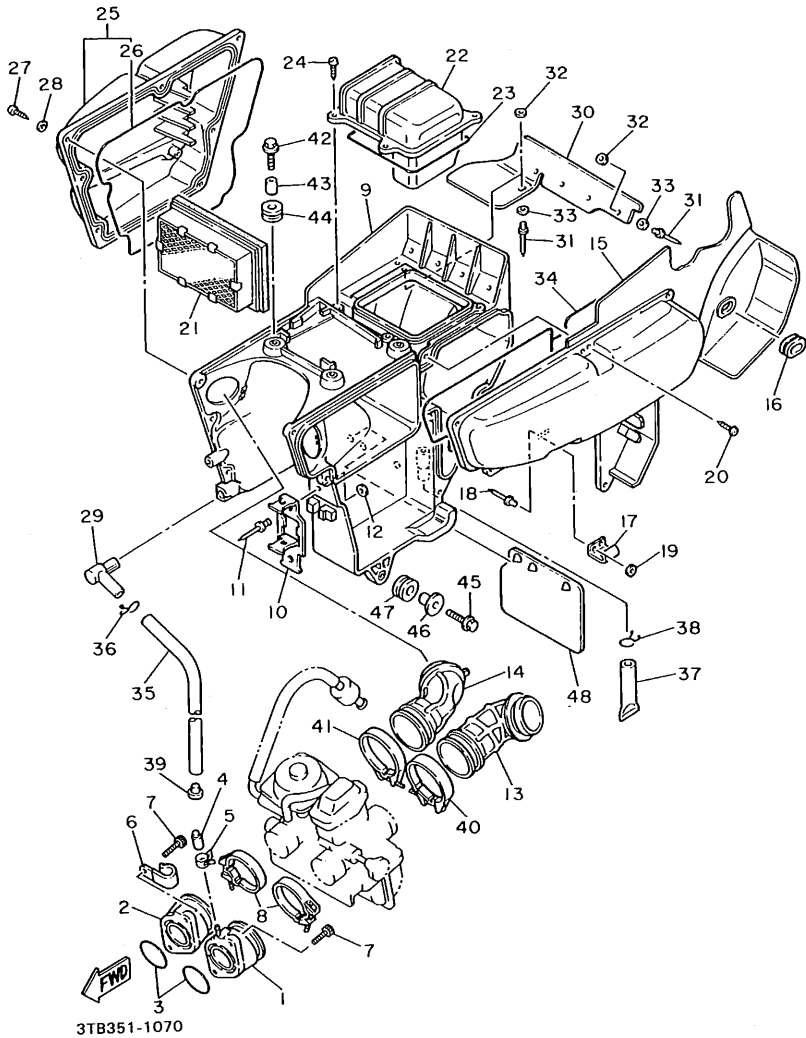

REF. NO.	PART NO.	DESCRIPTION	Q'TY	REMARKS
1	43F-13586-01	JOINT, carburetor 1	1	
2	1VJ-13596-00	JOINT, carburetor 2	1	
3	93210-36549	O-RING	2	
4	16G-13569-00	PLUG, blind	1	
5	90467-10039	CLIP	1	
6	90465-08028	CLAMP	1	
7	91316-06020	BOLT	4	
8	90460-46206	CLAMP, hose	2	
9	3TB-14411-00	CASE, air cleaner 1	1	
10	3TB-81953-00	STAY, relay	1	
11	90267-40075	RIVET, blind	1	
12	92901-04600	WASHER, plate	1	
13	3TB-14453-00	JOINT, air cleaner 1	1	
14	3TB-14454-00	JOINT	1	
15	3TB-1441A-00	COVER, cleaner case 1	1	
16	90480-12325	GROMMET	1	
17	43G-14436-00	HOOK	1	
18	90267-40075	RIVET, blind	2	
19	92901-04600	WASHER, plate	2	
20	97706-50520	SCREW, tapping	7	
21	3TB-14451-00	ELEMENT, air cleaner	1	
22	3TB-14412-00	CAP, cleaner case 1	1	
23	3TB-14457-00	SEAL	1	
24	97706-50520	SCREW, tapping	4	
25	3TB-1441E-00	COVER, cleaner case 2	1	
26	3TB-1446R-00	SEAL	1	
27	98506-05020	SCREW, pan head	7	
28	92906-05600	WASHER, plate	7	

FIG. 7 INTAKE

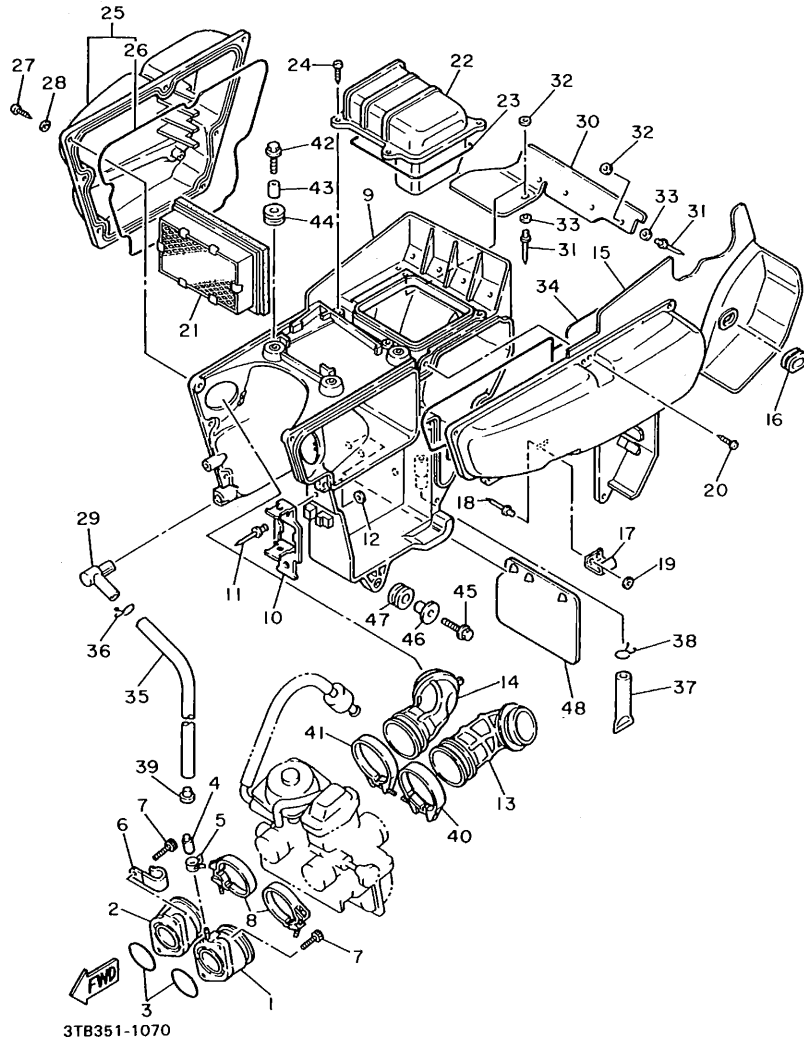

REF. NO.	PART NO.	DESCRIPTION	Q'TY	REMARKS
29	5Y1-14419-00	PIPE	1	
30	3TB-21621-00	FLAP	1	
31	90267-40077	RIVET, blind	5	
32	90201-047A2	WASHER, plate	5	
33	92990-04200	WASHER, plain	5	
34	3TB-14452-00	SEAL	1	
35	90445-126G6	HOSE	1	
36	90467-12052	CLIP	1	
37	34X-1443E-00	PIPE, drain	1	
38	90467-11102	CLIP	1	
39	90338-08174	PLUG	1	
40	90460-51059	CLAMP, hose	1	
41	90460-58015	CLAMP, hose	1	
42	95811-06020	BOLT, flange	3	
43	90387-06033	COLLAR	3	
44	90480-14329	GROMMET	3	
45	95816-06025	BOLT, flange	1	
46	90387-074X3	COLLAR	1	
47	90480-15064	GROMMET	1	
48	34X-21691-00	FLAP	1	

FIG. 8 CARBURETOR

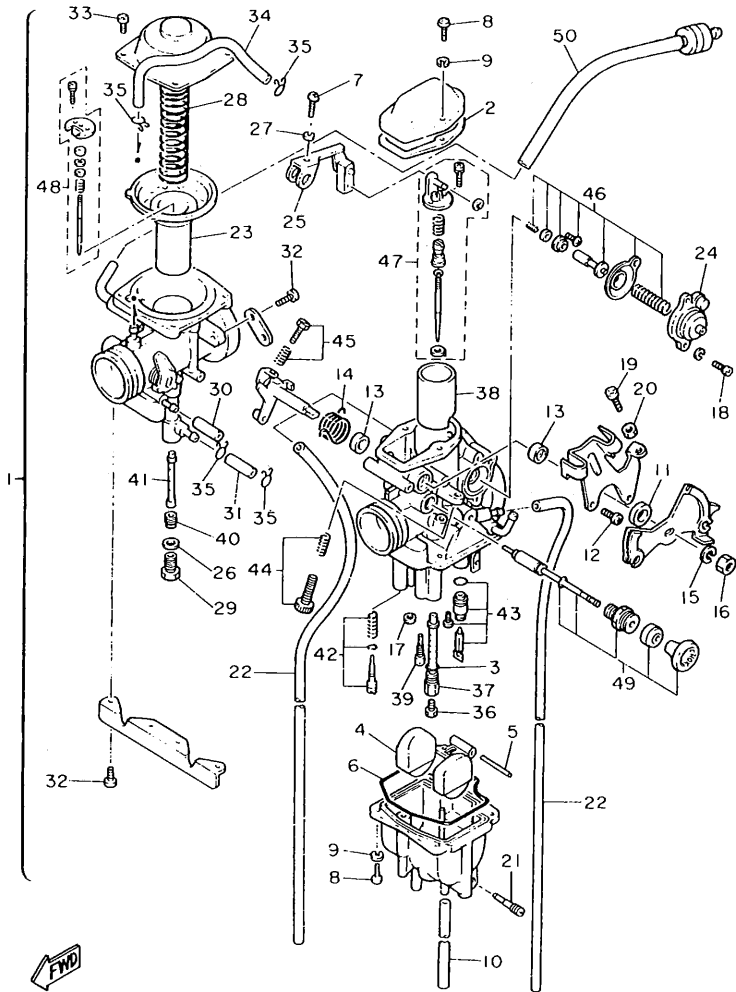

REF. NO.	PART NO.	DESCRIPTION	Q'TY	REMARKS
1	3TB-14301-00	CARBURETOR ASSY 1	1	
2	5Y1-14198-00	.GASKET	1	
3	360-24512-00	.GASKET	2	
4	2JN-14385-00	.FLOAT	1	
5	6E5-14386-01	.PIN, float	1	
6	5Y1-14384-00	.GASKET, float chamber	1	
7	98580-04016	.SCREW, pan head	1	
8	98503-04014	.SCREW, pan head	6	
9	92902-04100	.WASHER, spring	6	
10	1JK-14197-00	.PIPE	1	
11	1JK-14357-00	.COLLAR	1	
12	98580-04010	.SCREW, pan head	2	
13	5Y1-14572-00	.SEAL	2	
14	1XL-14131-00	.SPRING, throttle valve	1	
15	5Y1-14356-00	.WASHER, spring	1	
16	5Y1-14358-00	.NUT	1	
17	5Y1-14536-00	.GASKET	1	
18	98580-04010	.SCREW, pan head	2	
19	98580-04020	.SCREW, pan head	1	
20	30X-14358-00	.NUT	1	
21	14T-14323-00	.SCREW, air adjusting	1	
22	1VJ-14197-00	.PIPE	2	
23	1JK-14940-01	.DIAPHRAGM ASSY	1	
24	2JN-14293-00	.COVER 1	1	
25	1JK-14291-00	.CONNECTER COMP.	1	
26	7KF-14227-00	.WASHER	1	
27	92990-04100	.WASHER, spring	1	
28	1VJ-14286-00	.SPRING	1	

3TB332-0080

FIG. 8 CARBURETOR

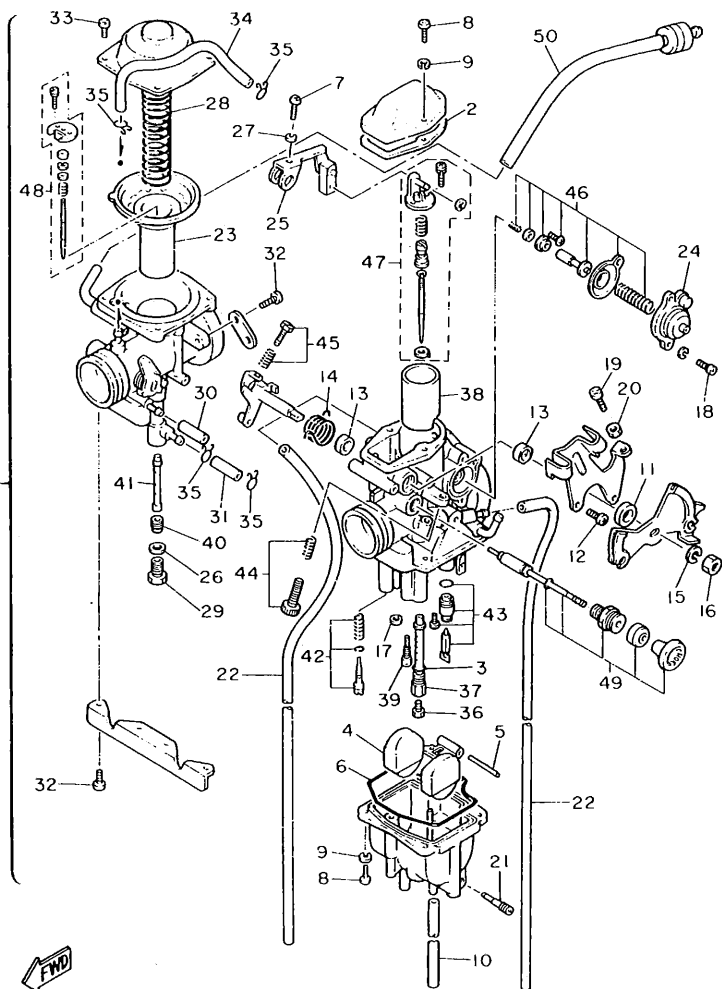

3TB332-0080

REF. NO.	PART NO.	DESCRIPTION	Q'TY	REMARKS
29	7KF-14162-00	.BOLT, holding	1	
30	5Y1-14349-00	.PIPE	1	
31	30X-14148-00	.PIPE	1	
32	98501-05010	.SCREW, pan head	6	
33	98580-04010	.SCREW, pan head	4	
34	5Y1-14149-00	.PIPE	1	
35	5Y1-14159-00	.CLIP	4	
36	288-14343-65	.JET, main (# 130)	1	UR STD
	288-14343-60	.JET, main (# 120)	1	UR
	288-14343-70	.JET, main (# 140)	1	UR
37	2KF-14341-00	.NOZZLE, main	1	
38	1JK-14313-55	.VALVE, throttle 2	1	
39	43F-14342-25	.JET, pilot (# 50)	1	
40	30X-14343-55	.JET, main (# 110)	1	
41	2KF-14355-00	.NOZZLE, main 2	1	
42	51Y-14105-00	.PILOT SCREW SET	1	
43	2JN-14107-00	.NEEDLE VALVE SET	1	
44	3GV-1490K-00	.STOP SCREW SET	1	
45	2NX-14103-00	.THROTTLE SCREW SET	1	
46	1JK-1490A-00	.DIAPHRAGM SET, 1	1	
47	3TB-1490J-10	.NEEDLE SET	1	
48	3TB-1490J-00	.NEEDLE SET	1	
49	2KF-1410A-00	.STARTER SET	1	
50	3TD-14197-00	PIPE	1	

FIG. 9 EXHAUST

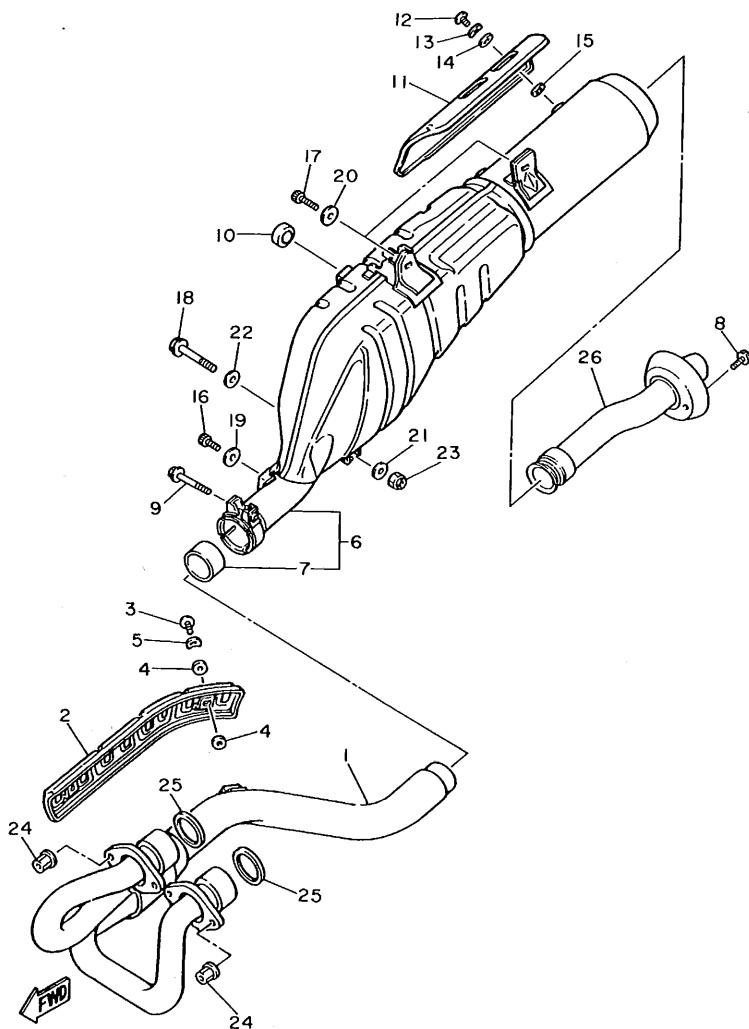

3TB351-2090

REF. NO.	PART NO.	DESCRIPTION	Q'TY	REMARKS
1	34K-14611-01	PIPE, exhaust 1	1	
2	34K-14628-01	PROTECTOR, exhaust pipe	1	
3	90164-06017	SCREW, tapping	2	
4	4BD-14766-00	WASHER, protector	4	
5	90206-06090	WASHER, wave	2	
6	3TB-14711-01	MUFFLER 1	1	
7	3YF-14755-00	GASKET	1	
8	91316-06012	BOLT	1	
9	95816-08045	BOLT, flange	1	
10	22W-24181-00	DAMPER, locating 1	1	
11	3TB-14728-00	PROTECTOR, muffler 2	1	
12	98980-06010	SCREW, bind	2	
13	90206-06090	WASHER, wave	2	
14	4BD-14766-00	WASHER, protector	2	
15	4BD-14766-00	WASHER, protector	2	
16	90109-085E2	BOLT	1	
17	90105-10186	BOLT, washer based	2	
18	90105-10232	BOLT, washer based	1	
19	90201-08326	WASHER, plate	1	
20	90201-102J5	WASHER, plate	2	
21	90201-101J1	WASHER, plate	1	
22	90201-10144	WASHER, plate	1	
23	95611-10200	NUT, self-locking	1	
24	90179-06499	NUT	4	
25	3YF-14613-00	GASKET, exhaust pipe	2	
26	3TB-14752-00	PIPE, outlet	1	

B15

FIG. 10 CRANKCASE

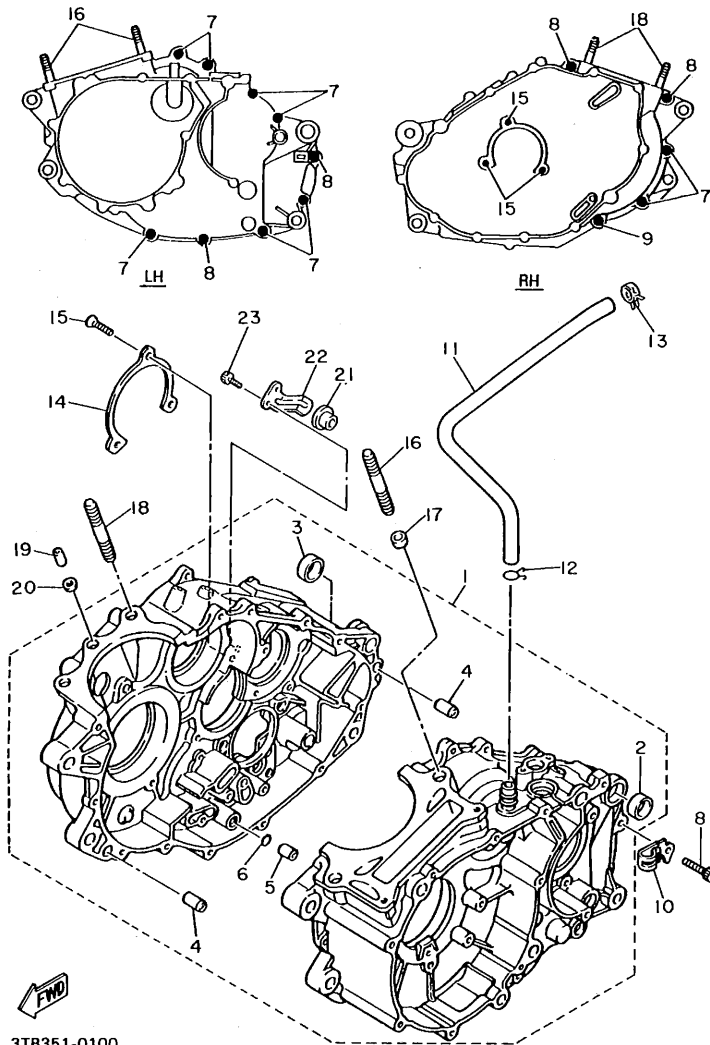

3TB351-0100

REF. NO.	PART NO.	DESCRIPTION	Q'TY	REMARKS
1	3DS-15100-00	CRANKCASE ASSY	1	CIRCUIT SILVER
2	90387-17783	.COLLAR	1	
3	90387-16782	.COLLAR	1	
4	99510-12016	.PIN, dowel	2	
5	99510-08016	.PIN, dowel	1	
6	93210-07135	.O-RING	1	
7	90110-06138	BOLT, hexagon socket head	9	
8	91316-06045	BOLT	4	
9	91316-06060	BOLT	1	
10	90465-08344	CLAMP	1	
11	3TB-11166-00	PIPE, breather 1	1	
12	90467-14015	CLIP	1	
13	90467-17128	CLIP	1	
14	5Y1-15383-00	PLATE, bearing cover	1	
15	98701-06012	SCREW, flat head	3	
16	90116-10506	BOLT, stud	2	
17	99510-14016	PIN, dowel	2	
18	90116-10263	BOLT, stud	2	
19	99510-08016	PIN, dowel	1	
20	90430-08178	GASKET	1	
21	3Y6-15167-00	PLUG, blind 1	1	
22	3Y6-15144-00	PLATE, lock	1	
23	97011-06016	BOLT	2	

FIG. 11 CRANKCASE COVER 1

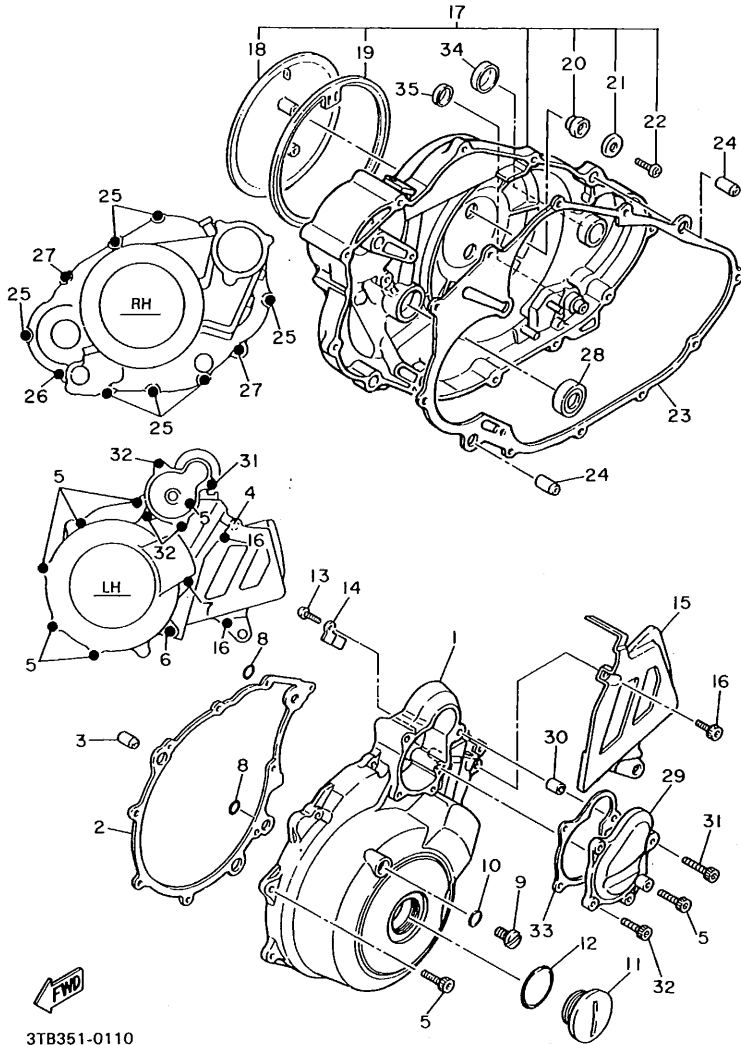

3TB351-0110

REF. NO.	PART NO.	DESCRIPTION	Q'TY	REMARKS
1	3TB-15411-01	COVER, crankcase 1	1	
2	4DW-15451-00	GASKET, crankcase cover 1	1	
3	99510-12016	PIN, dowel	2	
4	91316-06035	BOLT	1	
5	91316-06025	BOLT	6	
6	91316-06050	BOLT	1	
7	91316-06050	BOLT	1	
8	93210-13361	O-RING	2	
9	90340-08M04	PLUG, straight screw	1	
10	90430-08143	GASKET	1	
11	90340-36121	PLUG, straight screw	1	CIRCUIT SILVER
12	93210-36510	O-RING	1	
13	98501-06012	SCREW, pan head	1	
14	90462-16102	CLAMP	1	
15	3AJ-15421-00	COVER, crankcase 2	1	CIRCUIT SILVER
16	91316-06016	BOLT	2	
17	3DS-15430-00	CRANKCASE COVER ASSY 3	1	CIRCUIT SILVER
18	2WK-15418-01	.COVER, chain case	1	
19	1JK-15449-00	.RING, rubber	1	
20	1JK-15486-00	.GROMMET	2	
21	90209-05279	.WASHER	2	
22	98501-05010	.SCREW, pan head	2	
23	4DW-15462-00	GASKET, crankcase cover 3	1	
24	99510-12016	PIN, dowel	2	
25	91316-06025	BOLT	7	
26	90110-06138	BOLT, hexagon socket head	1	
27	91316-06035	BOLT	2	
28	93101-14092	OIL SEAL (S7-14-25-5.5-1-HS)	1	

FIG. 11 CRANKCASE COVER 1

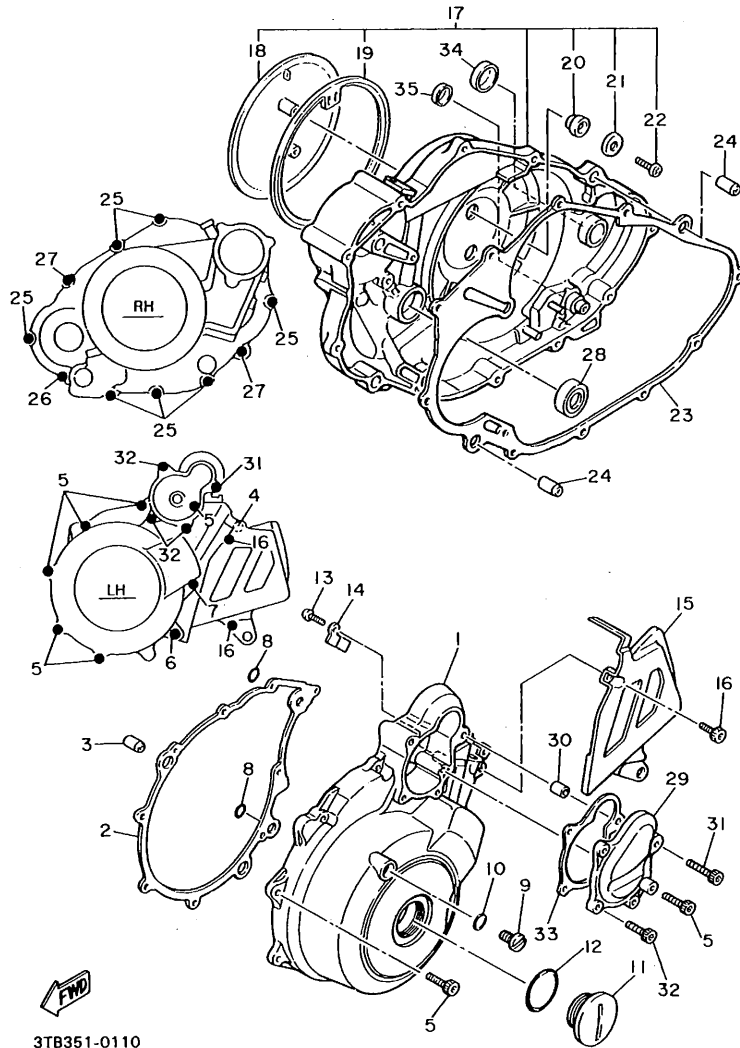

3TB351-0110

REF. NO.	PART NO.	DESCRIPTION	Q'TY	REMARKS
29	3TB-15415-00	COVER, generator	1	
30	99510-08016	PIN, dowel	1	
31	91316-06035	BOLT	1	
32	91316-06025	BOLT	3	
33	4DW-15455-00	GASKET 1	1	
34	90338-30096	PLUG	1	
35	90338-21100	PLUG	1	

FIG. 12 STARTER CLUTCH

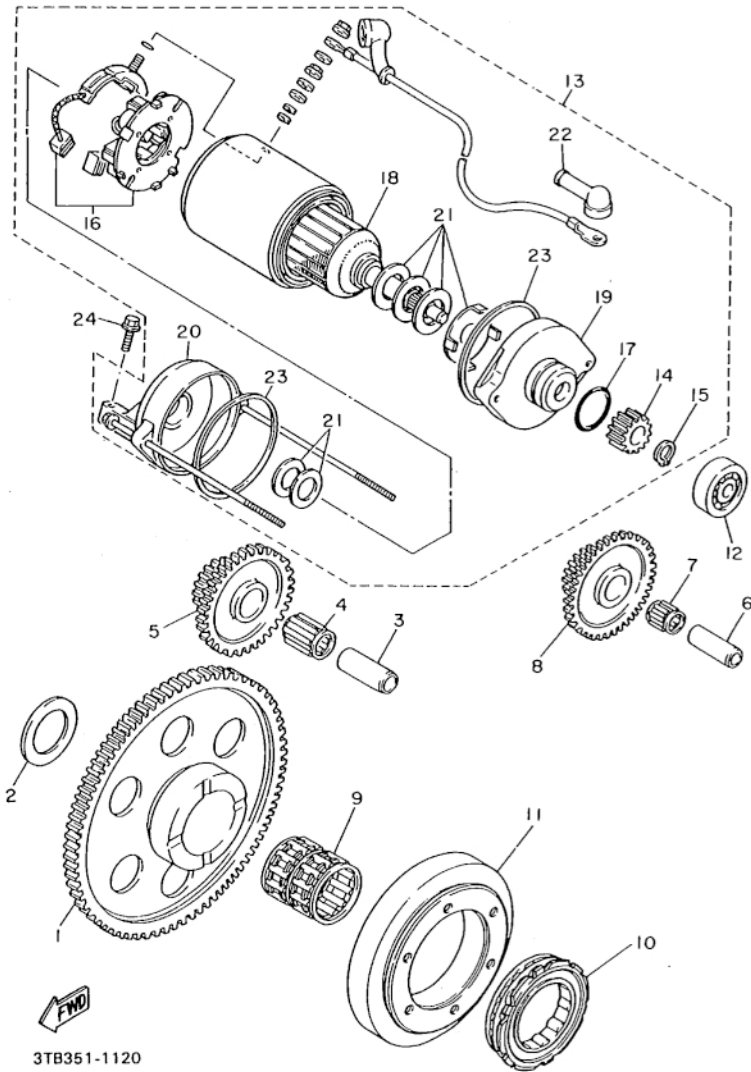

3TB351-1120

REF. NO.	PART NO.	DESCRIPTION	Q'TY	REMARKS
1	3TB-15515-00	GEAR 3	1	
2	90201-303P4	WASHER, plate	1	
3	1VJ-15522-00	SHAFT 2	1	
4	93310-217R7	BEARING, cylindrical	1	
5	1VJ-15517-00	GEAR, idler 2	1	
6	1VJ-15521-00	SHAFT 1	1	
7	93310-212R6	BEARING, cylindrical	1	
8	1VJ-15512-00	GEAR, idler 1	1	
9	93310-530C7	BEARING, cylindrical	1	
10	3TB-15590-00	STARTER ONE-WAY ASSY	1	
11	3TB-15594-00	RACE, one-way bearing	1	
12	93306-20006	BEARING (B6200)	1	NTN
13	3TB-81800-00	STARTING MOTOR ASSY	1	
14	1VJ-15511-00	.GEAR, starting motor	1	
15	93440-11024	.CIRCLIP	1	
16	3AJ-81801-00	.BRUSH SET	1	
17	26H-81847-00	.O-RING	1	
18	3AJ-81850-00	.ARMATURE ASSY	1	
19	3AJ-81830-00	.FRONT BRACKET ASSY	1	
20	3AJ-81820-00	.REAR BRACKET ASSY	1	
21	3AJ-81809-00	.WASHER KIT	1	
22	4G0-81871-00	.CAP	1	
23	11H-81844-00	.GASKET	2	
24	95811-06030	BOLT, flange	2	

FIG. 13 CLUTCH

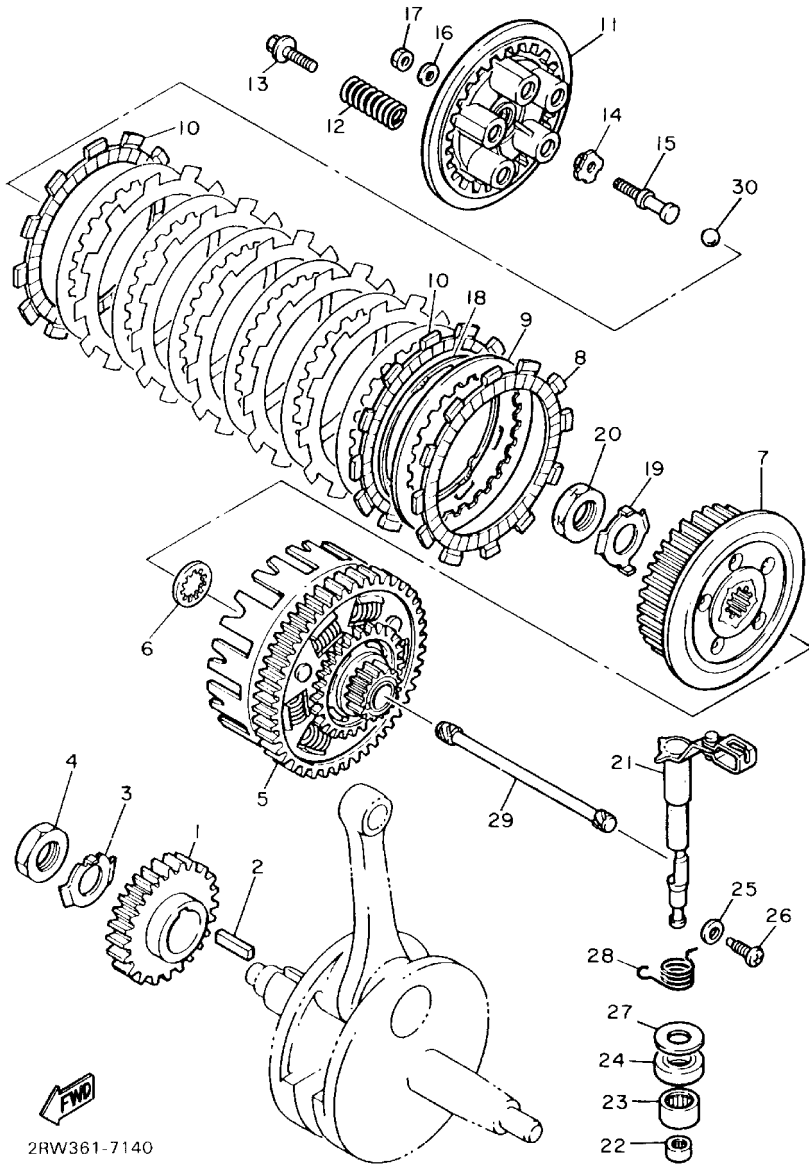

2RW361-7140

REF. NO.	PART NO.	DESCRIPTION	Q'TY	REMARKS
1	3AJ-16111-00	GEAR, primary drive (34T)	1	
2	90282-07042	KEY, straight	1	
3	90215-20197	WASHER, lock	1	
4	90170-20274	NUT	1	
5	3AJ-16150-00	PRIMARY DRIVEN GEAR COMP.(71T)	1	
6	2JN-16154-00	PLATE, thrust 1	1	
7	2JN-16371-00	BOSS, clutch	1	
8	5Y1-16321-00	PLATE, friction	6	
9	360-16325-00	PLATE, clutch 2	7	
10	5Y1-16331-01	PLATE, friction 2	2	
11	5Y1-16351-00	PLATE, pressure 1	1	
12	90501-23142	SPRING, compression	5	
13	90159-06010	SCREW, with washer	5	
14	30X-16358-00	PLATE, push	1	
15	34K-16356-00	ROD, push 1	1	
16	92901-06200	WASHER, plain	1	
17	95303-06600	NUT	1	
18	5Y1-16383-00	SPRING, clutch boss	1	
19	90215-20231	WASHER, lock	1	
20	90170-20327	NUT	1	
21	1VJ-16380-01	PUSH LEVER ASSY	1	
22	93317-11020	BEARING, cylindrical	1	
23	93315-11720	BEARING, cylindrical	1	
24	93102-17357	OIL SEAL	1	
25	90201-08087	WASHER, plate	1	
26	90149-08067	SCREW	1	
27	90201-17327	WASHER, plate	1	
28	90508-14710	SPRING, torsion	1	

FIG. 13 CLUTCH

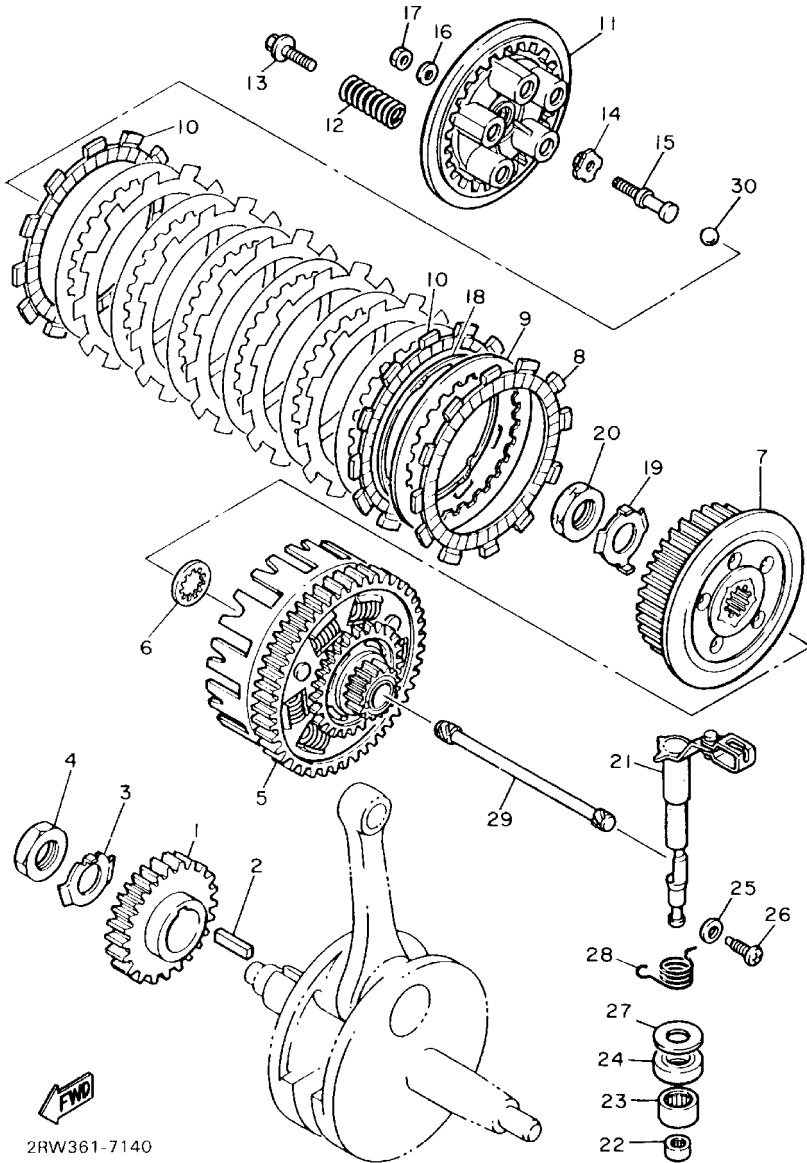

REF. NO.	PART NO.	DESCRIPTION	Q'TY	REMARKS
29	5Y1-16357-00	ROD, push 2	1	
30	93515-32029	BALL	1	

2RW361-7140

C7

FIG. 14 TRANSMISSION

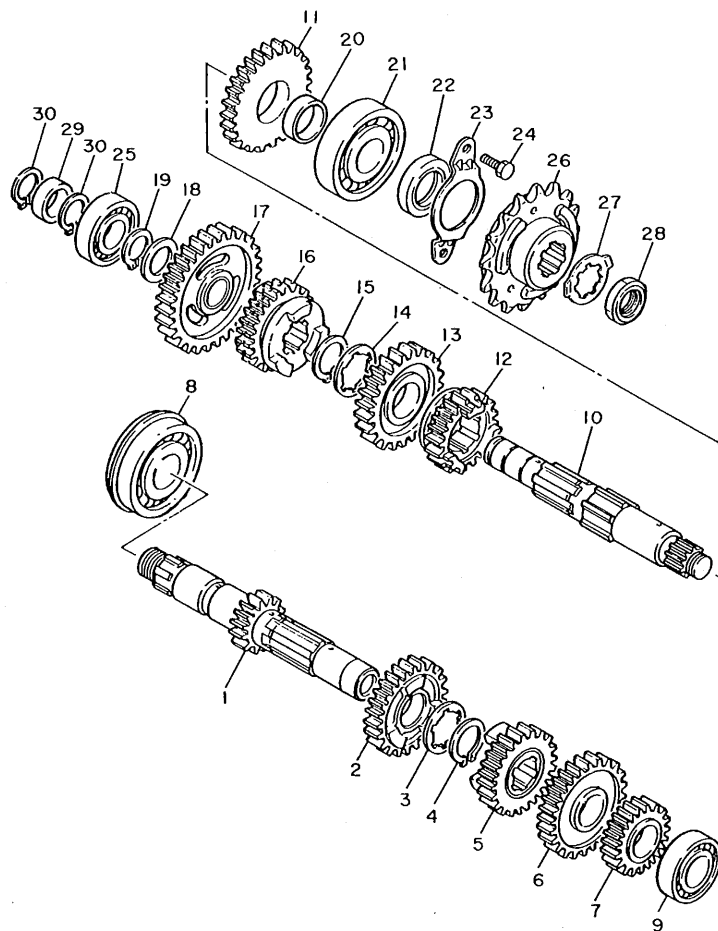

3AJ1351-8140

REF. NO.	PART NO.	DESCRIPTION	Q'TY	REMARKS
1	2RW-17411-00	AXLE, main (12T)	1	
2	34K-17141-00	GEAR, 4th pinion(22T)	1	
3	90209-22191	WASHER	1	
4	93440-25084	CIRCLIP	1	
5	1VJ-17131-00	GEAR, 3rd pinion (20T)	1	
6	2JT-17151-01	GEAR, 5th pinion (24T)	1	
7	34K-17121-01	GEAR, 2nd pinion (17T)	1	
8	93306-30540	BEARING (6305NRX1C3)	1	
9	93306-00431	BEARING	1	
10	2RW-17402-00	DRIVE AXLE ASSY	1	
11	2JT-17221-00	GEAR, 2nd wheel (27T)	1	
12	2JT-17251-00	GEAR, 5th wheel (19T)	1	
13	1VJ-17231-00	GEAR, 3rd wheel (24T)	1	
14	90209-22191	WASHER	1	
15	93440-25084	CIRCLIP	1	
16	3AJ-17241-00	GEAR, 4th wheel (21T)	1	
17	3AJ-17211-00	GEAR, 1st wheel (31T)	1	
18	90201-20276	WASHER, plate (1.0T)	1	
19	99009-20400	CIRCLIP	1	
20	90560-25283	SPACER	1	
21	93306-30535	BEARING	1	
22	93102-25226	OIL SEAL	1	
23	5Y1-17471-00	PLATE, cover	1	
24	97021-06014	BOLT	2	
25	93306-00426	BEARING	1	
26	99999-01798	SPROCKET, drive (15T)	1	
27	90215-23265	WASHER, lock	1	
28	90179-18552	NUT	1	

FIG. 14 TRANSMISSION

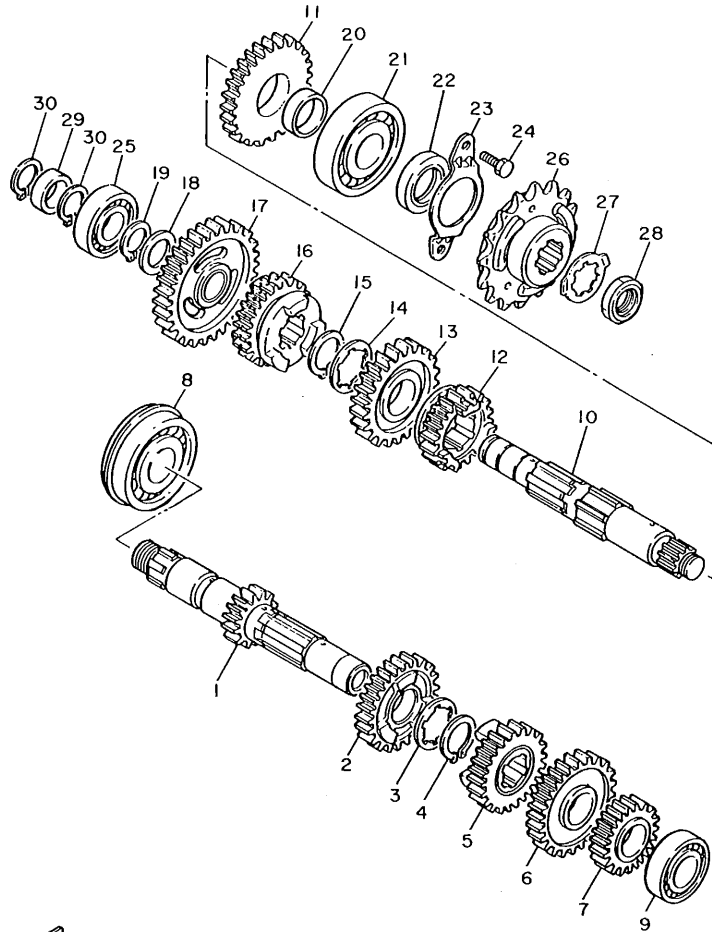

REF. NO.	PART NO.	DESCRIPTION	Q'TY	REMARKS
29	90560-20199	SPACER	1	
30	99009-20400	CIRCLIP	2	



3AJ1351-8140

C9

FIG. 15 SHIFT CAM • FORK

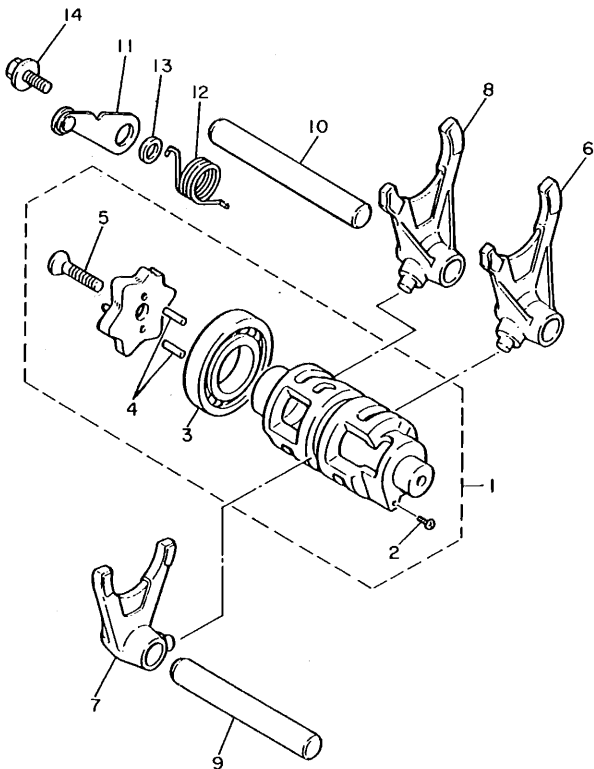

REF. NO.	PART NO.	DESCRIPTION	Q'TY	REMARKS
1	3YF-18540-00	SHIFT CAM ASSY	1	
2	136-18542-00	•POINT, neutral	1	
3	93316-00503	•BEARING, cylindrical	1	
4	93604-10011	•PIN, dowel	2	
5	90151-06017	•SCREW, countersunk	1	
6	5Y1-18511-00	FORK, shift 1	1	
7	5Y1-18512-00	FORK, shift 2	1	
8	5Y1-18513-00	FORK, shift 3	1	
9	34K-18531-00	BAR, shift fork guide 1	1	
10	34K-18535-00	BAR, shift fork guide 2	1	
11	34K-18140-00	STOPPER LEVER ASSY	1	
12	90508-26691	SPRING, torsion	1	
13	90387-063F7	COLLAR	1	
14	90159-06078	SCREW, with washer	1	



2KF300-7150

C10

FIG. 16 SHIFT SHAFT

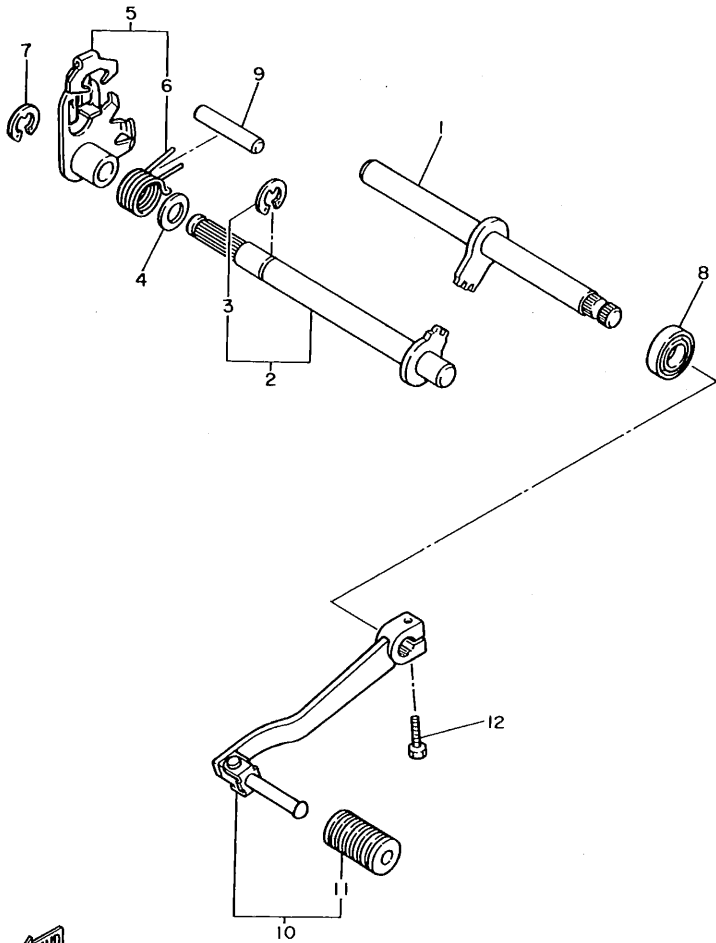

REF. NO.	PART NO.	DESCRIPTION	Q'TY	REMARKS
1	43F-18102-02	SHIFT SHAFT ASSY 2	1	
2	5Y1-18101-02	SHIFT SHAFT ASSY	1	
3	99006-10600	•CIRCLIP	1	
4	90201-12474	WASHER, plate	1	
5	34K-18120-00	SHIFT LEVER ASSY	1	
6	90508-29629	•SPRING, torsion	1	
7	99001-09600	CIRCLIP	1	
8	93102-12106	OIL SEAL (SD 12-22-5 HS)	1	
9	93608-33046	PIN, dowel	1	
10	1VJ-18110-01	SHIFT PEDAL ASSY	1	
11	1W6-18113-00	•COVER, shift pedal	1	
12	97016-06020	BOLT	1	



3TB351-0160

C11

FIG. 17 FRAME

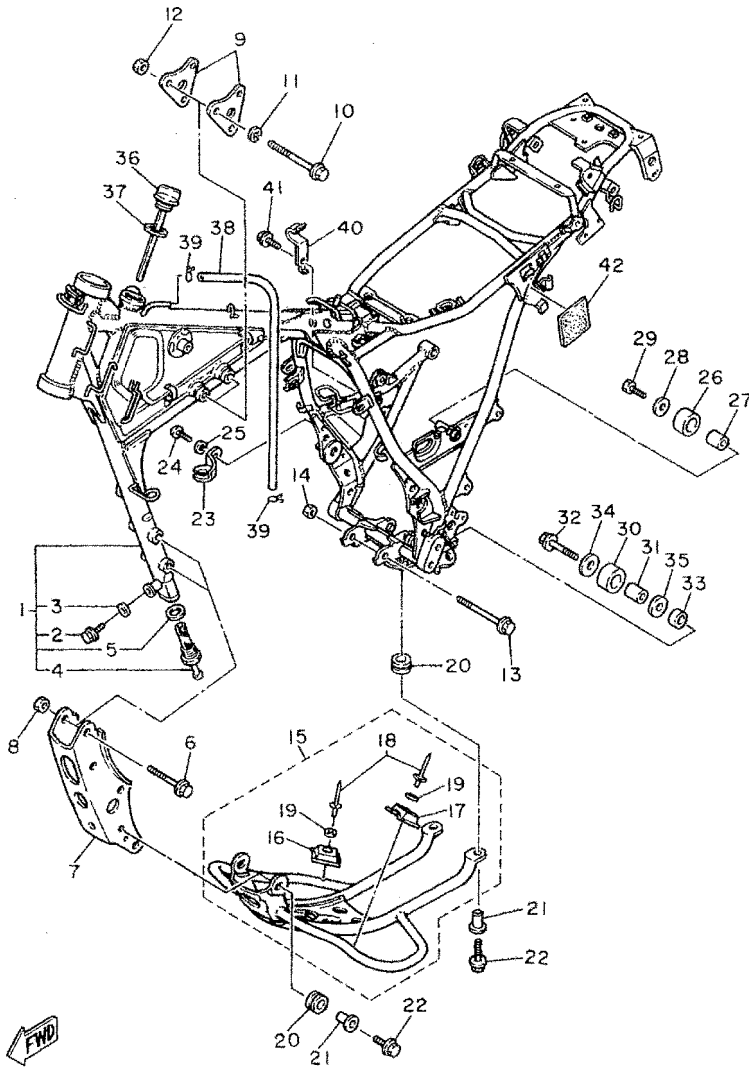

3TB351-0171

REF. NO.	PART NO.	DESCRIPTION	Q'TY	REMARKS
1	3YP-21110-00-WL	FRAME COMP.	1	STARDUST SILVER
2	95811-08012	.BOLT, flange	1	
3	90201-08087	.WASHER, plate	1	
4	3TB-21756-00	.NET, filter	1	
5	90430-22123	.GASKET	1	
6	90105-10286	BOLT, washer based	4	
7	3TB-21316-00-WL	STAY, engine 3	1	STARDUST SILVER
8	90185-10060	NUT, self-locking	4	
9	34L-21315-00	STAY, engine 2	2	
10	97011-10080	BOLT	3	
11	92901-10100	WASHER, spring	3	
12	90185-10060	NUT, self-locking	3	
13	95811-10100	BOLT, flange	1	
14	90185-10060	NUT, self-locking	1	
15	3TB-W2147-00-WL	PROTECTOR, engine	1	STARDUST SILVER
16	34K-21485-00	.DAMPER, rubber 1	1	
17	34K-21486-00	.DAMPER 2	1	
18	90267-40075	.RIVET, blind	2	
19	90201-04M06	.WASHER, plate	2	
20	90480-15363	GROMMET	4	
21	90387-07391	COLLAR	4	
22	95811-06025	BOLT, flange	4	
23	5Y1-21441-00	BRACKET, stop switch	1	
24	92506-06012	SCREW, pan head	1	
25	92906-06100	WASHER, spring	1	
26	3TB-22178-00	TENSIONER	1	
27	4V4-22184-00	BUSH	1	
28	90201-08753	WASHER, plate	1	

FIG. 17 FRAME

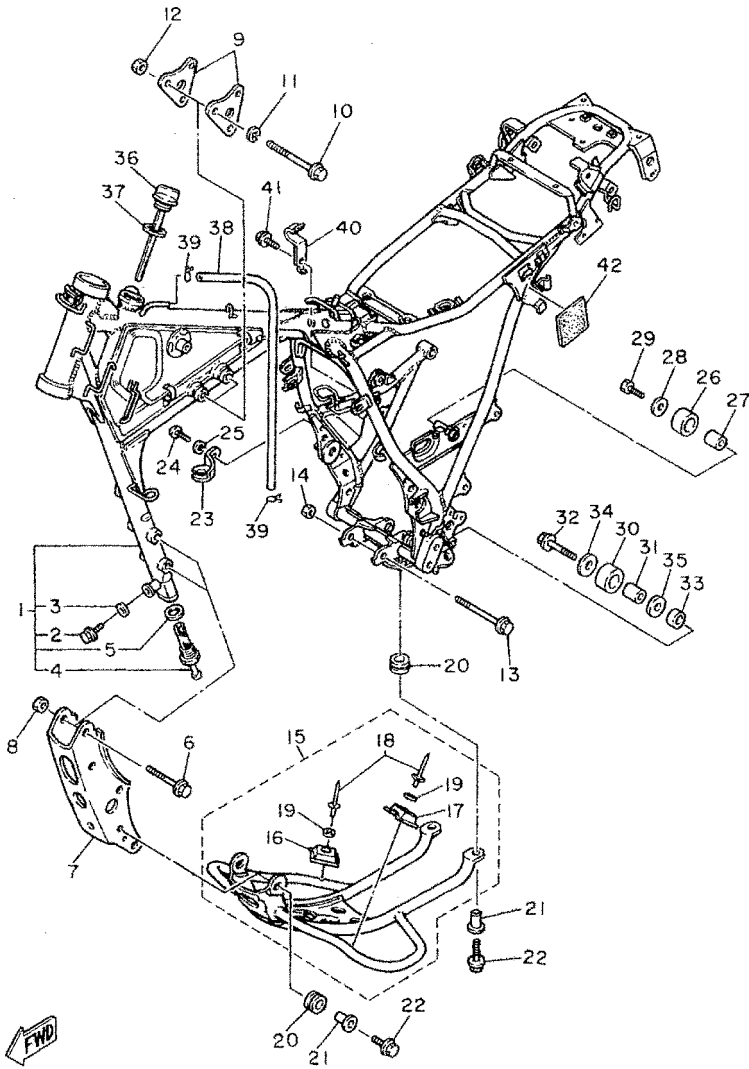

REF. NO.	PART NO.	DESCRIPTION	Q'TY	REMARKS
29	95023-08016	BOLT	1	
30	30X-22178-00	TENSIONER	1	
31	4V4-22184-00	BUSH	1	
32	90109-08705	BOLT	1	
33	90201-13409	WASHER, plate	1	
34	90201-08753	WASHER, plate	1	
35	90387-085E1	COLLAR	1	
36	3TB-21771-00	BODY, cap	1	
37	90430-27124	GASKET	1	
38	90445-115G3	HOSE	1	
39	90467-10008	CLIP	2	
40	3TB-21338-00	CLAMP	1	
41	91026-06010	BOLT	1	
42	3TB-28415-00	DAMPER 1	1	

3TB351-0171

FIG. 18 FENDER

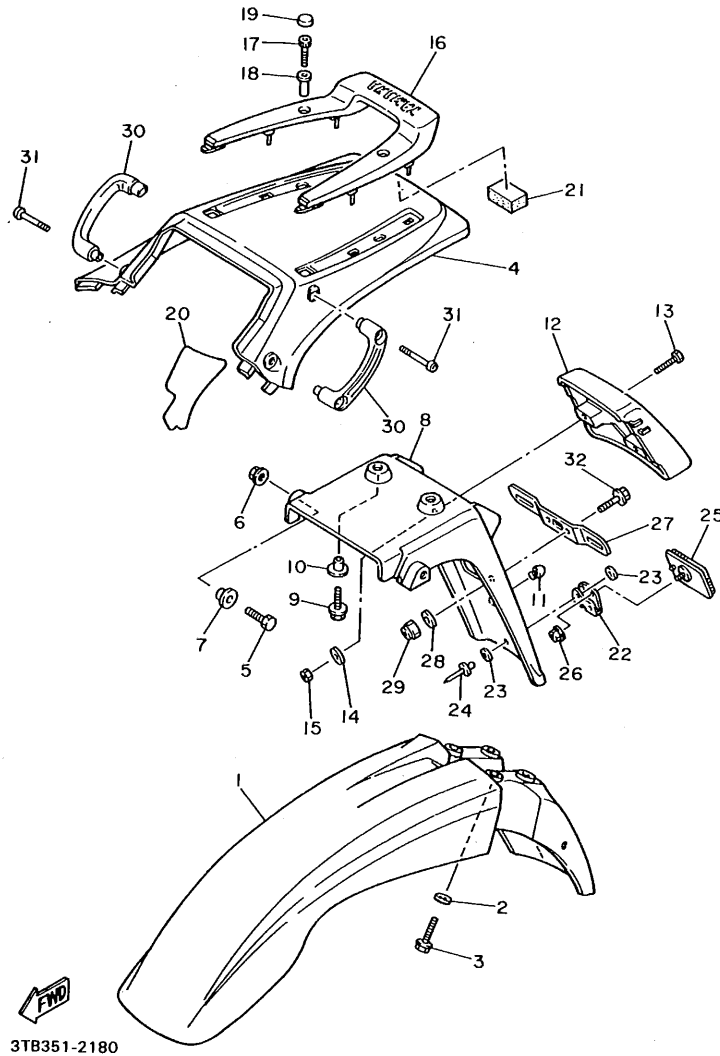

REF. NO.	PART NO.	DESCRIPTION	Q'TY	REMARKS
1	3RW-21511-40	FENDER, front	1	UR FARAWAY BLUE
	3RW-21511-60	FENDER, front	1	UR PURPLISH WHITE SOLID 1
	3RW-21511-70	FENDER, front	1	UR YAMAHA BLACK
2	90387-062V8	COLLAR	4	
3	90119-06097	BOLT, with washer	4	
4	3TB-21611-40	FENDER, rear	1	UR FARAWAY BLUE
	3TB-21611-60	FENDER, rear	1	UR PURPLISH WHITE SOLID 1
	3TB-21611-70	FENDER, rear	1	UR YAMAHA BLACK
5	98006-06016	BOLT	2	
6	95706-06500	NUT, flange	2	
7	90387-07717	COLLAR	2	
8	2KF-21685-01	BRACKET, license	1	
9	90119-06061	BOLT, with washer	2	
10	90387-066M3	COLLAR	2	
11	42U-21639-00	DAMPER 2	1	
12	3TB-2163A-00	COVER, rear fender 1	1	
13	98006-06025	BOLT	2	
14	90201-06059	WASHER, plate	2	
15	95316-06600	NUT	2	
16	3TB-21651-00	COVER, rear fender	1	
17	91311-06025	BOLT	2	
18	90387-062M3	COLLAR	2	
19	90336-18038	PLUG, taper	2	
20	3TB-2174T-00	INSULATOR, side cover 2	1	
21	3TB-21639-00	DAMPER 2	1	
22	33G-85132-00	BRACKET, reflector 1	1	
23	90201-044A2	WASHER, plate	4	
24	90267-40090	RIVET, blind	2	

FIG. 18 FENDER

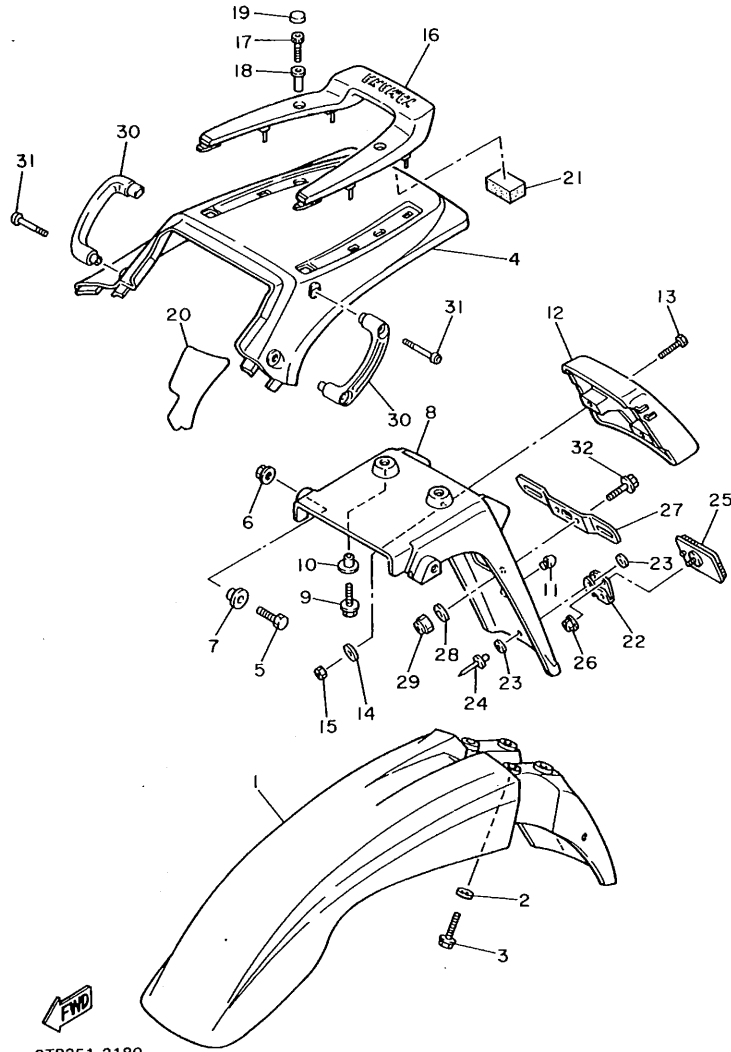

3TB351-2180

REF. NO.	PART NO.	DESCRIPTION	Q'TY	REMARKS
25	3G1-85130-01	REAR REFLECTOR ASSY	1	
26	95701-05500	NUT, flange	1	
27	3YF-84751-00	BRACKET, license	1	'UNI-CHROME (BLACK CHROMATE)
28	90201-06059	WASHER, plate	2	
29	95616-06100	NUT, u	2	
30	3TB-2164F-00	STAY 1	2	
31	92016-08050	SCREW	4	
32	95026-06012	BOLT, flange	2	

C15

FIG. 19 SIDE COVER

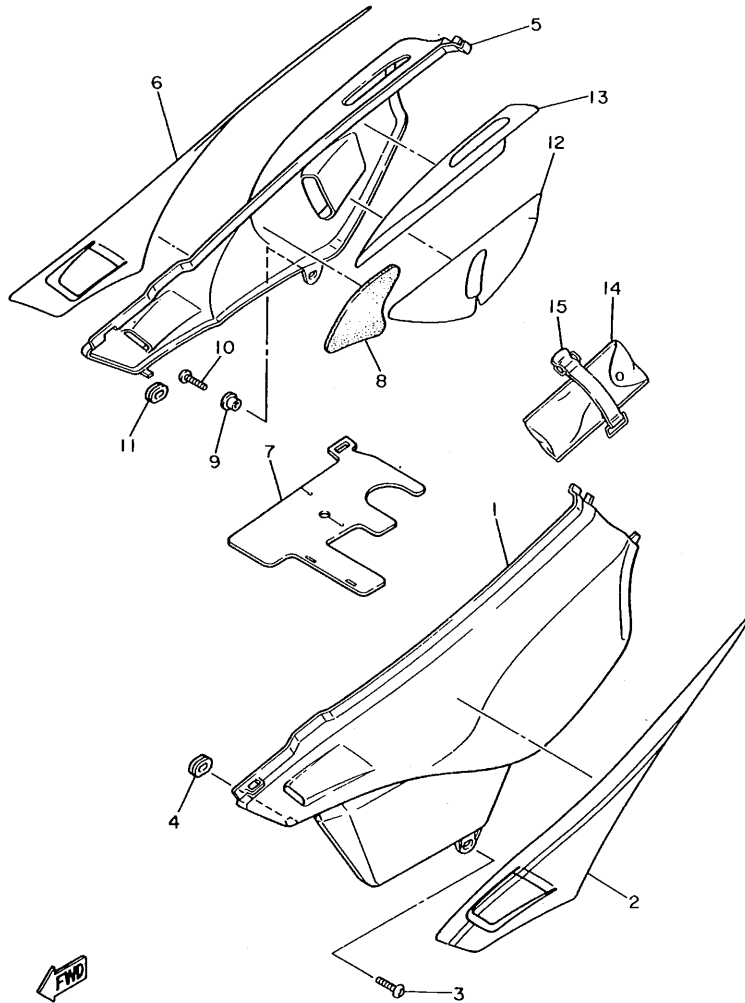

3TB351-2190

REF. NO.	PART NO.	DESCRIPTION	Q'TY	REMARKS
1	3TB-21711-40	COVER, side 1	1	UR FARAWAY BLUE
	3TB-21711-60	COVER, side 1	1	UR PURPLISH WHITE SOLID 1
	3TB-21711-70	COVER, side 1	1	UR YAMAHA BLACK
2	3TB-2173L-60	GRAPHIC SET 1	1	UR FOR FWB
	3TB-2173L-70	GRAPHIC SET 1	1	UR FOR PWS 1
	3TB-2173L-80	GRAPHIC SET 1	1	UR FOR YB
3	90149-06223	SCREW	1	
4	90480-01176	GROMMET	1	
5	3TB-21721-40	COVER, side 2	1	UR FARAWAY BLUE
	3TB-21721-60	COVER, side 2	1	UR POURPLISH WHITE SOLID 1
	3TB-21721-70	COVER, side 2	1	UR YAMAHA BLACK
6	3TB-2174L-60	GRAPHIC SET 2	1	UR FOR FWB
	3TB-2174L-70	GRAPHIC SET 2	1	UR FOR PWS 1
	3TB-2174L-80	GRAPHIC SET 2	1	UR FOR YB
7	3TB-2177F-00	COVER	1	
8	3TB-21542-00	DAMPER 2	1	
9	90387-061V4	COLLAR	1	
10	90149-06223	SCREW	1	
11	90480-01176	GROMMET	1	
12	3TB-2174A-00	INSULATOR, side cover	1	
13	3TB-2174A-10	INSULATOR, side cover	1	
14	3TB-28100-00	TOOL KIT	1	
15	46X-21376-00	BAND, tool	1	

D2

FIG. 20 REAR ARM

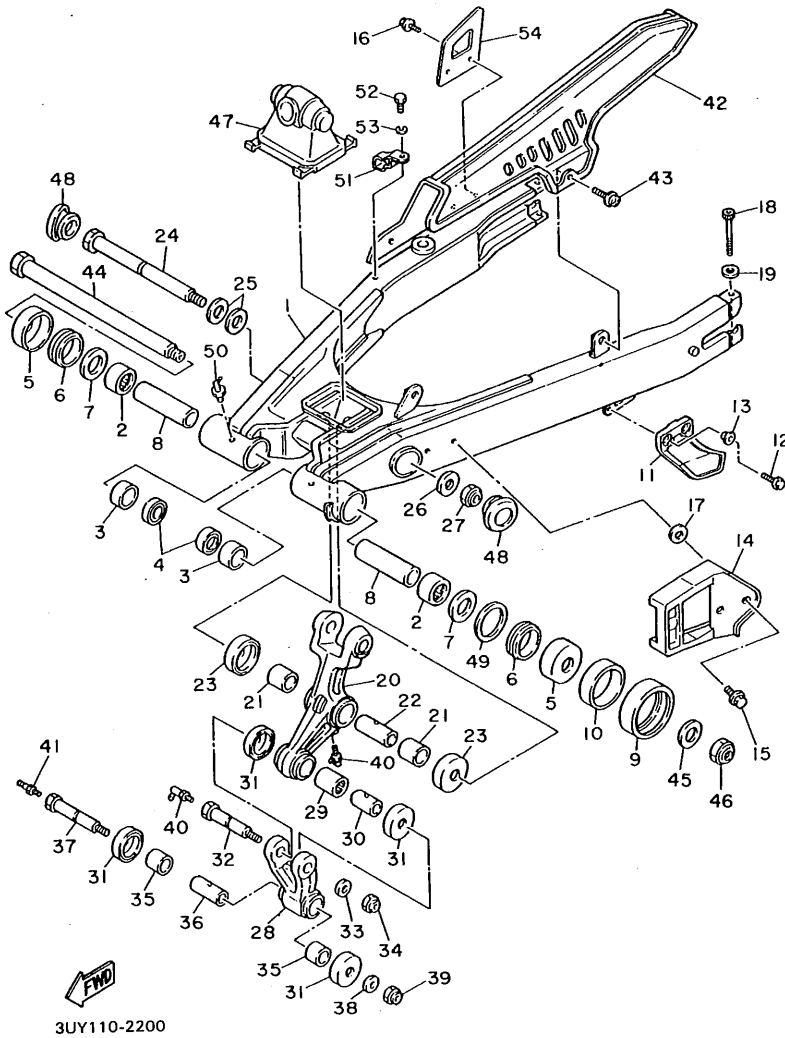

REF. NO.	PART NO.	DESCRIPTION	Q'TY	REMARKS
1	3TB-22110-01-P0	REAR ARM COMP.	1	GRAY METALLIC 1
2	93317-32231	BEARING, cylindrical	2	
3	90380-22111	BUSH, solid	2	
4	93106-22019	OIL SEAL (DC 22-28-8)	2	
5	2K6-22128-01	COVER, thrust 1	2	
6	93108-35004	OIL SEAL (35-41-8)	2	
7	90201-244A8	WASHER, plate (1.95T)	2	
8	1VJ-22123-00	BUSH 1	2	
9	5X6-22151-10	SEAL, guard	1	
10	90387-440G3	COLLAR	1	
11	38V-22199-00	SUPPORT, chain	1	
12	95811-06020	BOLT, flange	2	
13	90387-06737	COLLAR	2	
14	2KF-22147-00	PROTECTOR, chain	1	
15	95826-06012	BOLT, flange	2	
16	95801-06010	BOLT, flange	2	
17	90209-06223	WASHER	2	
18	91311-06060	BOLT	2	
19	92901-06600	WASHER, plate	2	
20	3TB-2217A-00	ARM, relay	1	
21	90386-20120	BUSH	2	
22	90380-14095	BUSH, solid	1	
23	34L-22128-00	COVER, thrust 1	2	
24	90105-12668	BOLT, washer based	1	
25	90201-140G9	WASHER, plate	2	
26	90201-120A5	WASHER, plate	1	
27	95611-12100	NUT, u	1	
28	34L-2217F-00	ROD, connecting 1	1	

FIG. 20 REAR ARM

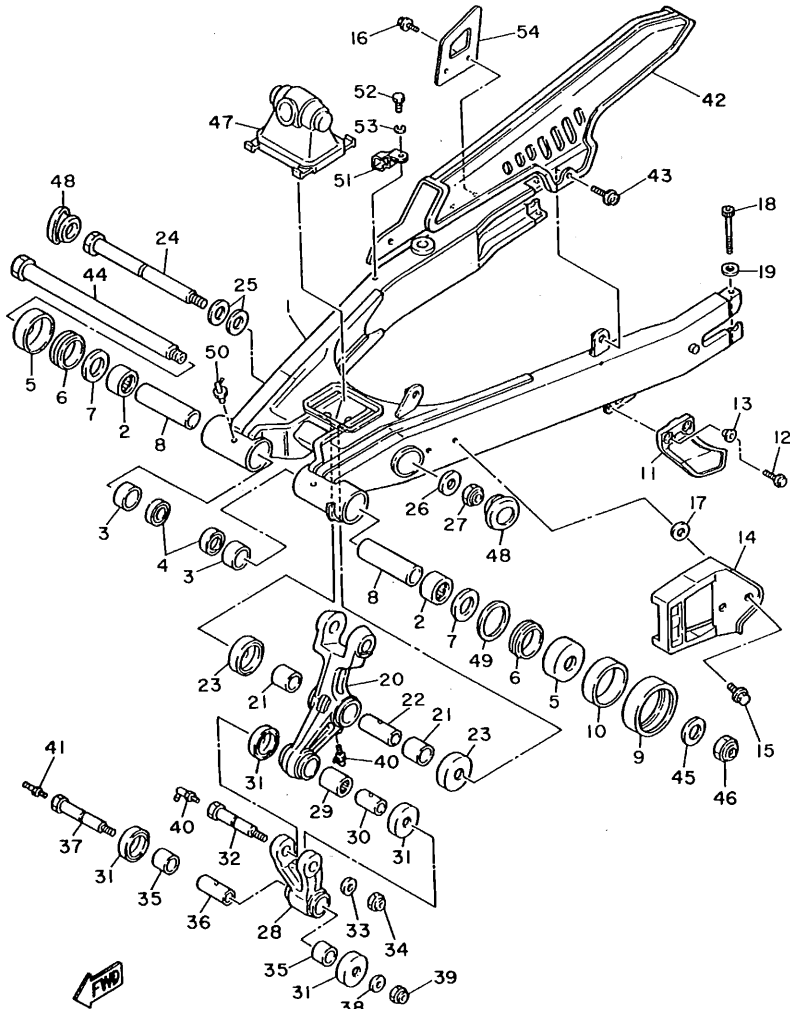

3UY110-2200

REF. NO.	PART NO.	DESCRIPTION	Q'TY	REMARKS
29	93315-31732	BEARING, cylindrical	1	
30	90387-121H1	COLLAR	1	
31	23X-22129-00	COVER, thrust 2	4	
32	90109-10759	BOLT	1	
33	90201-100E9	WASHER, plate	1	
34	90185-10120	NUT, self-locking	1	
35	90386-20123	BUSH	2	
36	90387-122J6	COLLAR	1	
37	90109-10760	BOLT	1	
38	90201-100F7	WASHER, plate	1	
39	90185-10037	NUT, self-locking	1	
40	93700-06005	NIPPLE, grease	2	
41	93700-06004	NIPPLE, grease	1	
42	3TB-22311-00	CASE, chain	1	
43	90159-06084	SCREW, with washer	2	
44	1VJ-22141-00	SHAFT, pivot	1	
45	90201-15238	WASHER, plate	1	
46	90185-14070	NUT, self-locking	1	
47	3TB-22189-00	BOOT, rubber	1	
48	34L-22117-00	CAP	2	
49	90201-251F6	WASHER, plate (0.3T)	1	
50	93700-06005	NIPPLE, grease	2	
51	90461-12110	CLAMP	1	
52	97003-06012	BOLT	1	
53	92990-06100	WASHER, spring	1	
54	2KF-27491-00	PROTECTOR	1	

FIG. 21 REAR ARM • SUSPENSION

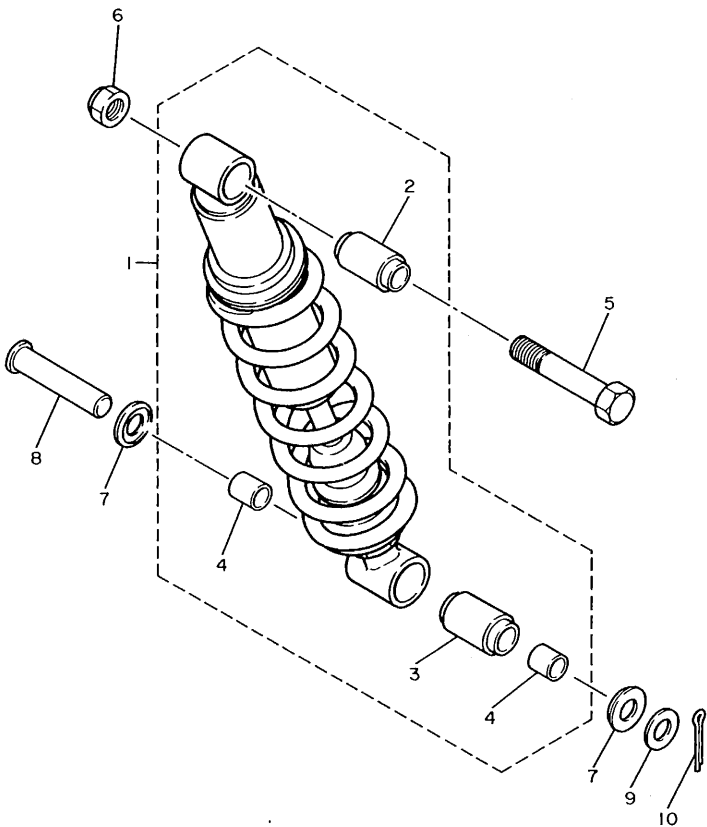

REF. NO.	PART NO.	DESCRIPTION	Q'TY	REMARKS
1	3TB-22210-00-33	SHOCK ABSORBER ASSY, rear	1	YAMAHA BLACK
2	34L-22216-00	•BUSH, rear shock absorber	1	
3	34L-22226-01	•BUSH, shock absorber lower	1	
4	90380-14130	•BUSH, solid	2	
5	90101-12295	BOLT	1	
6	95611-12100	NUT, u	1	
7	34L-22129-00	COVER, thrust 2	2	
8	90240-14106	PIN, clevis	1	
9	92990-14600	WASHER	1	
10	91401-30030	PIN, cotter	1	



3TB351-0210

D5

FIG. 22 STEERING

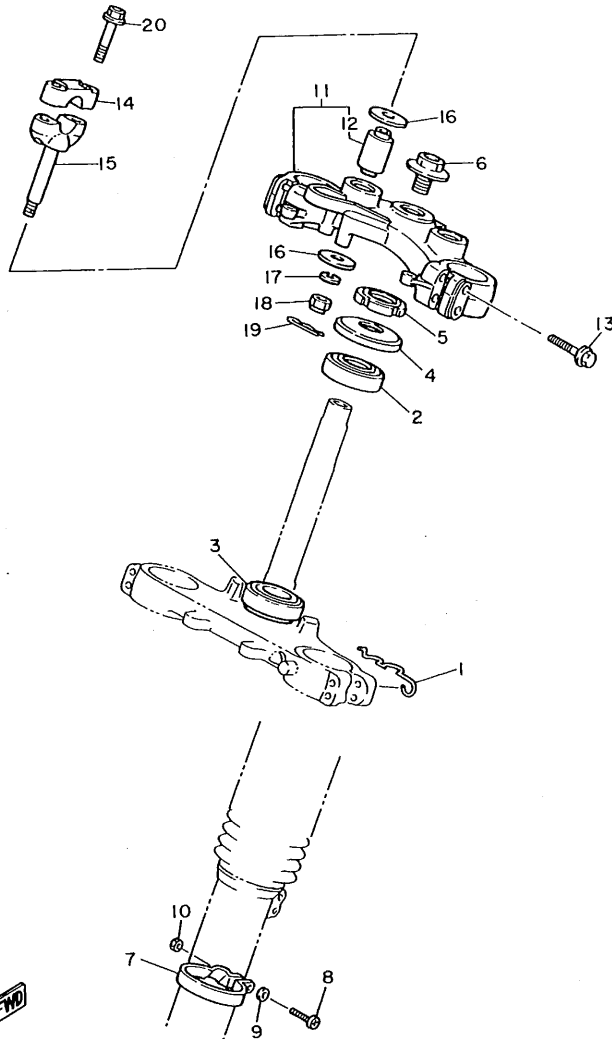

3UY110-2220

REF. NO.	PART NO.	DESCRIPTION	Q'TY	REMARKS
1	3TB-2331E-00	GUIDE, cable	1	
2	93332-00023	BEARING	1	
3	93332-00008	BEARING	1	
4	1W1-23416-00	COVER, ball race 2	1	
5	90179-25033	NUT	1	
6	90105-14102	BOLT, washer based	1	
7	34L-23318-01	HOLDER, cable 1	1	
8	98501-05020	SCREW, pan head	1	
9	92901-05600	WASHER, plate	1	
10	95303-05600	NUT	1	
11	3TB-W2341-00	CROWN, handle	1	
12	5A8-23434-00	HOLDER, damper	2	
13	91026-08040	BOLT	4	
14	1E6-23441-00	HOLDER, handle upper	2	
15	3Y6-23442-00-98	HOLDER, handle lower	2	LOW GLOSS BLACK
16	90201-100A1	WASHER, plate	4	
17	92901-10100	WASHER, spring	2	
18	95303-10700	NUT	2	
19	90468-12006	CLIP	2	
20	95816-08035	BOLT, flange	4	

D6

FIG. 23 FRONT FORK

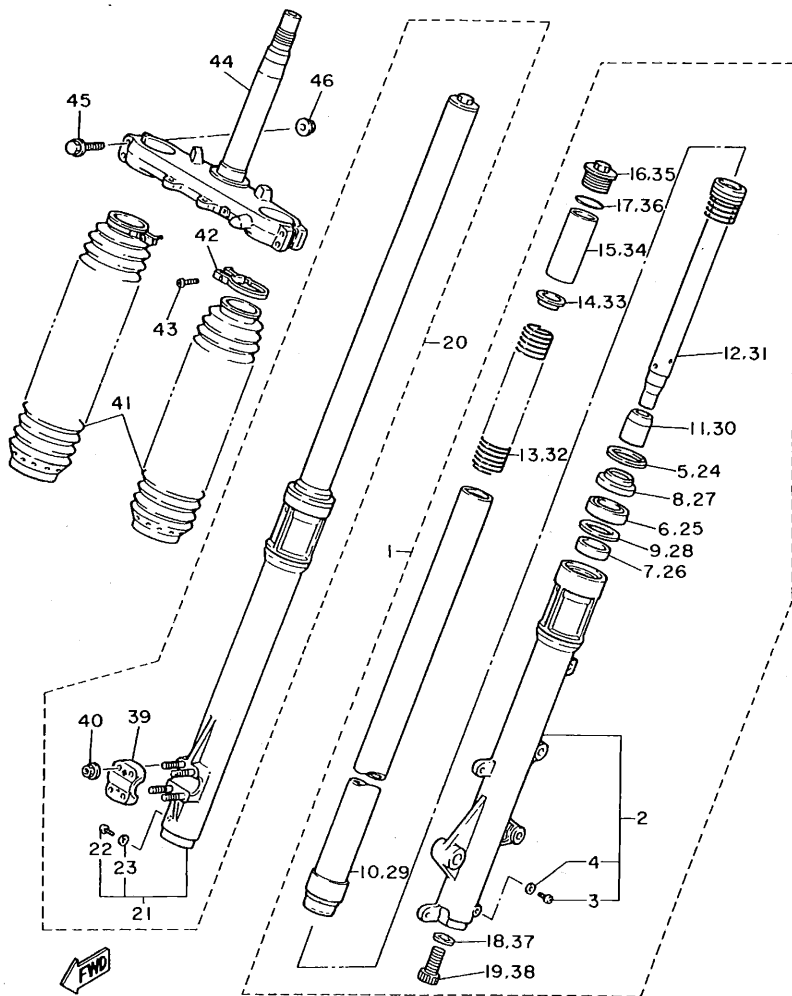

3TB351-0230

REF. NO.	PART NO.	DESCRIPTION	Q'TY	REMARKS
1	3TB-23102-00	FRONT FORK ASSY (L.H)	1	
2	3TB-23126-00	.TUBE, outer 1	1	
3	4H7-23119-00	..PLUG, drain	1	
4	122-23129-00	..GASKET, drain plug	1	
5	26H-23156-00	.CLIP, oil seal	1	
6	43F-23145-10	.OIL SEAL	1	
7	3LC-23125-00	.METAL, slide 1	1	
8	43F-23144-10	.SEAL, dust	1	
9	36Y-23146-10	.WASHER, oil seal	1	
10	3TB-23110-00	.INNER TUBE COMP.1	1	
11	3GM-23173-00	.SPINDLE, taper	1	
12	3TB-23170-00	.CYLINDER COMP., front fork	1	
13	3TB-23141-00	.SPRING, front fork	1	
14	43F-23142-10	.SEAT, spring upper	1	
15	3FW-23118-00	.SPACER	1	
16	3EN-23111-50	.BOLT, cap	1	
17	43F-23188-10	.O-RING	1	
18	4V4-23158-L0	.GASKET	1	
19	4V4-23181-L0	.BOLT, hexagon socket head	1	
20	3TB-23103-00	FRONT FORK ASSY (R.H)	1	
21	3TB-23136-00	.TUBE, outer 2	1	
22	4H7-23119-00	..PLUG, drain	1	
23	122-23129-00	..GASKET, drain plug	1	
24	26H-23156-00	.CLIP, oil seal	1	
25	43F-23145-10	.OIL SEAL	1	
26	3LC-23125-00	.METAL, slide 1	1	
27	43F-23144-10	.SEAL, dust	1	
28	36Y-23146-10	.WASHER, oil seal	1	

FIG. 23 FRONT FORK

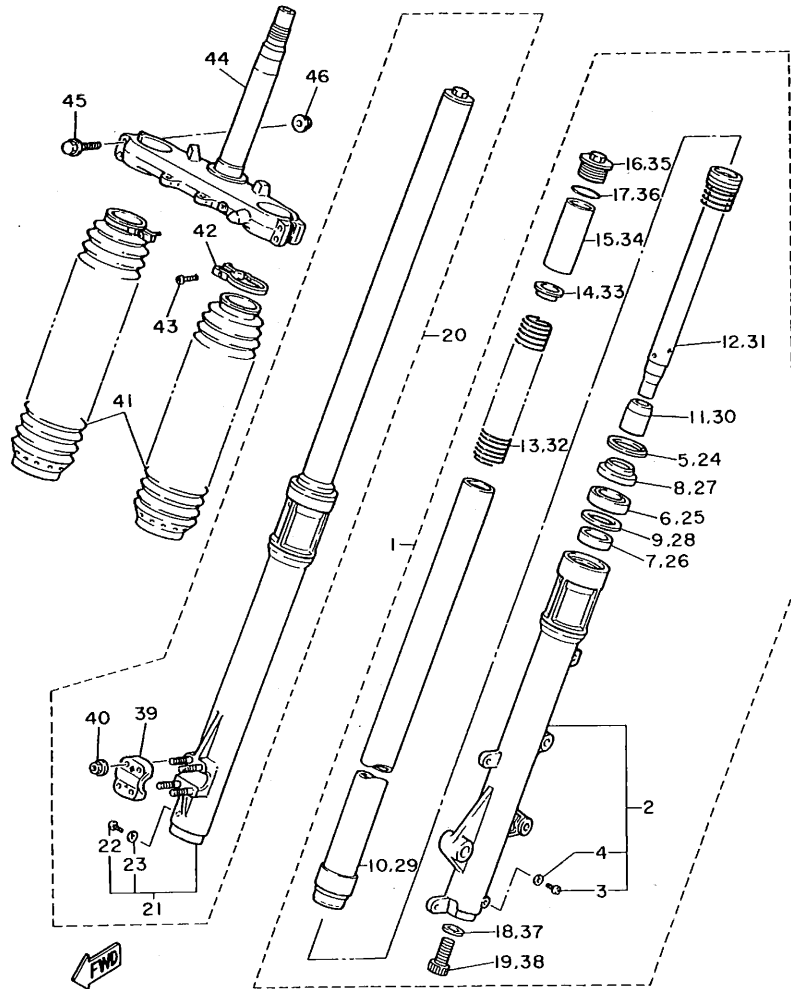

3TB351-0230

REF. NO.	PART NO.	DESCRIPTION	Q'TY	REMARKS
29	3TB-23110-00	.INNER TUBE COMP.1	1	
30	3GM-23173-00	.SPINDLE, taper	1	
31	3TB-23170-00	.CYLINDER COMP., front fork	1	
32	3TB-23141-00	.SPRING, front fork	1	
33	43F-23142-10	.SEAT, spring upper	1	
34	3FW-23118-00	.SPACER	1	
35	3EN-23111-50	.BOLT, cap	1	
36	43F-23188-10	.O-RING	1	
37	4V4-23158-L0	.GASKET	1	
38	4V4-23181-L0	.BOLT, hexagon socket head	1	
39	4V2-23167-L0	.HOLDER, axle	1	
40	2KF-23127-01	.NUT, outer tube	1	
41	3BN-23191-21	BOOT	2	UR BLUISH GREEN SOLID 1 FOR FWB
	3BJ-23191-01	BOOT	2	UR DEEP VIOLET SOLID 1 FOR YB, PWS 1
42	43M-23192-L0	BAND	2	
43	98506-04018	SCREW, pan head	2	
44	3TB-23340-00	UNDER BRACKET COMP.	1	
45	95811-08055	BOLT, flange	4	
46	95701-08500	NUT, flange	4	

FIG. 24 FUEL TANK

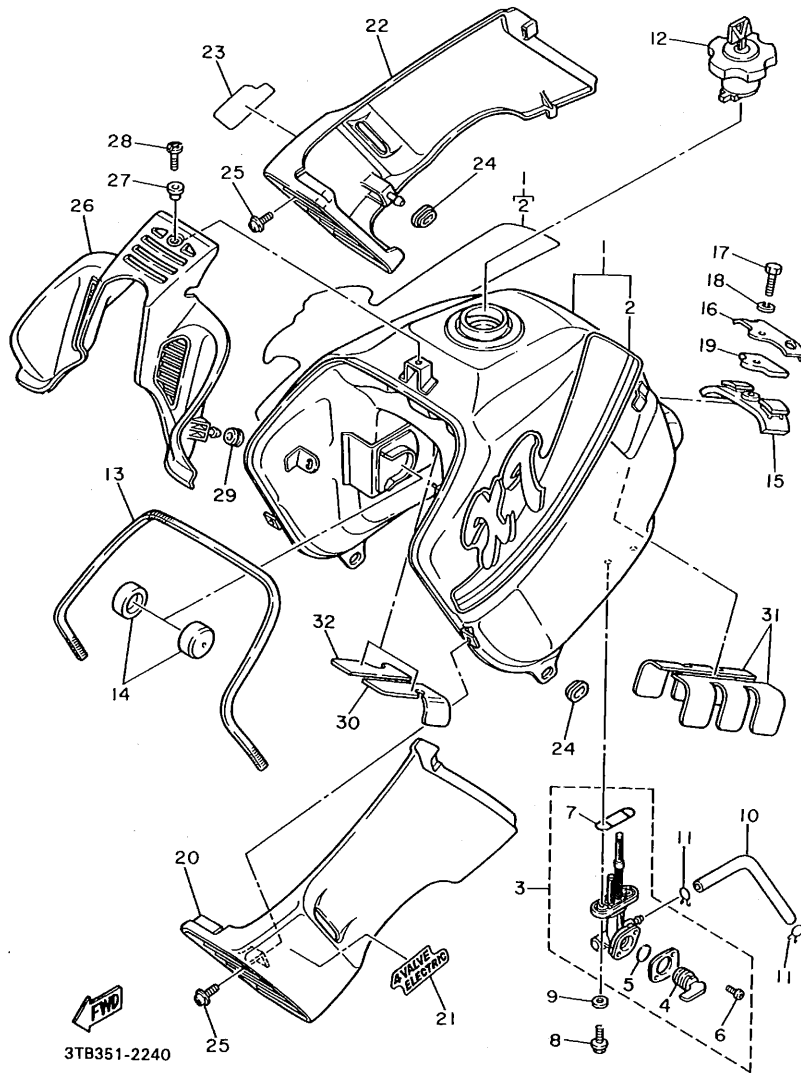

REF. NO.	PART NO.	DESCRIPTION	Q'TY	REMARKS
1	3TB-24110-00-X1	FUEL TANK COMP.	1	UR YAMAHA BLACK
	3TB-24110-00-08	FUEL TANK COMP.	1	UR FARAWAY BLUE
	3TB-24110-00-09	FUEL TANK COMP.	1	UR PURPLISH WHITE SOLID 1
2	3TB-24240-80	.GRAPHIC SET	1	UR FOR YB
	3TB-24240-60	.GRAPHIC SET	1	UR FOR FWB
	3TB-24240-70	.GRAPHIC SET	1	UR FOR PWS 1
3	3FY-24500-00	FUEL COCK ASSY 1	1	
4	3AJ-24523-00	.VALVE	1	
5	3AJ-24534-00	.SEAL, cock	1	
6	98503-03008	.SCREW, pan head	2	
7	4X8-24512-00	.O-RING	1	
8	95023-06016	BOLT	2	
9	90202-05193	WASHER, plate	2	
10	90445-10638	HOSE	1	
11	90467-09006	CLIP	2	
12	11H-24602-02	CAP ASSY	1	
13	3TB-24188-00	MOLD, fuel tank	1	
14	3TB-24181-00	DAMPER, locating 1	2	
15	43F-24182-00	DAMPER, locating 2	1	
16	3TB-24186-00	WASHER, special	1	
17	97313-06016	BOLT	1	
18	92990-06100	WASHER, spring	1	
19	23T-24724-01	DAMPER, seat	1	
20	3TB-2137W-00	SCOOP, air 1	1	UR RADICAL GRAY FOR YB
	3TB-2137W-40	SCOOP, air 1	1	UR YAMAHA BLACK FOR FWB
	3TB-2137W-60	SCOOP, air 1	1	UR VIVID MAGENTA SOLID 2 FOR PWS 1
21	3TB-24231-80	EMBLEM 1	1	UR FOR YB
	3TB-24231-60	EMBLEM 1	1	UR FOR FWB

3TB351-2240

D9

FIG. 24 FUEL TANK

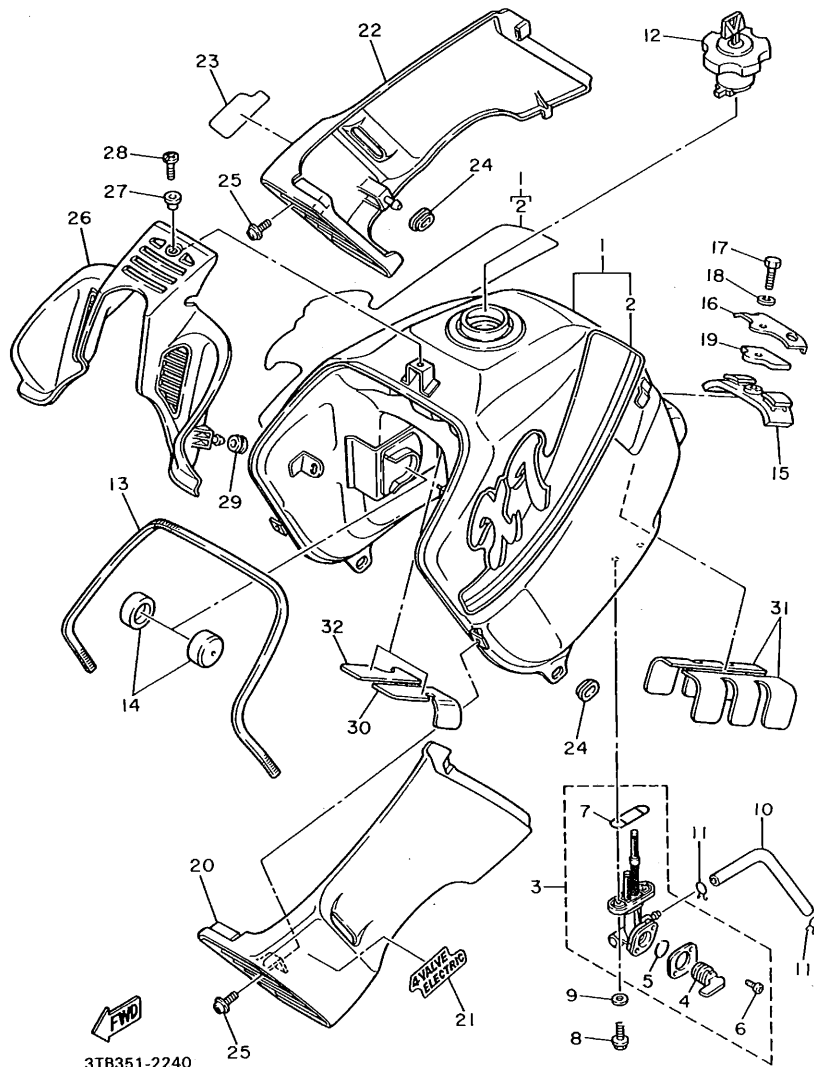

REF. NO.	PART NO.	DESCRIPTION	Q'TY	REMARKS
21	3TB-24231-70	EMBLEM 1	1	UR FOR PWS 1
22	3TB-2137X-00	SCOOP, air 2	1	UR RADICAL GRAY FOR YB
	3TB-2137X-40	SCOOP, air 2	1	UR YAMAHA BLACK FOR FWB
	3TB-2137X-60	SCOOP, air 2	1	UR VIVID MAGENTA SOLID 2 FOR PWS 1
23	3TB-24232-80	EMBLEM 2	1	UR FOR YB
	3TB-24232-60	EMBLEM 2	1	NON-OCEANIA
	3TB-24232-70	EMBLEM 2	1	UR FOR PWS 1
24	90480-01401	GROMMET	2	
25	90159-06042	SCREW, with washer	2	
26	3TB-2137Y-00	GUIDE, air	1	
27	90387-064J1	COLLAR	1	
28	90149-06223	SCREW	1	
29	90480-13383	GROMMET	2	
30	3TB-2416F-00	INSULATOR, fuel tank 1	1	
31	3TB-2416G-00	INSULATOR, fuel tank 2	2	
32	3TB-2416F-10	INSULATOR, fuel tank 1	1	

FIG. 25 SEAT

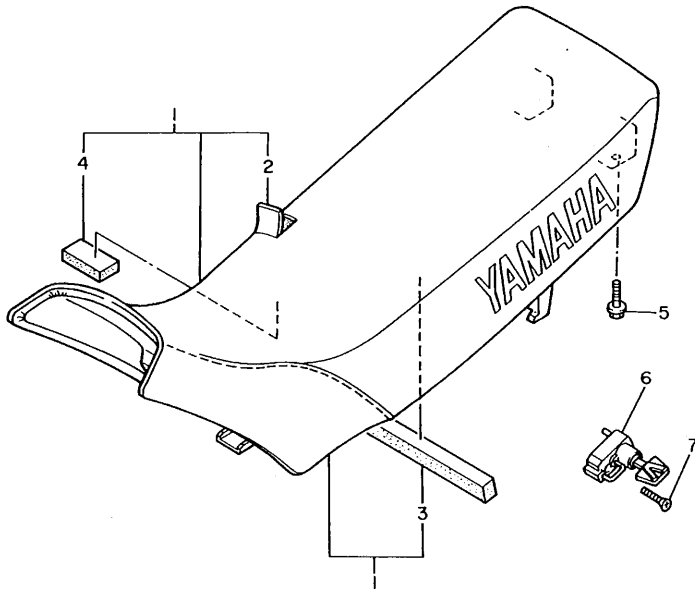

REF. NO.	PART NO.	DESCRIPTION	QTY	REMARKS
1	3TB-24770-40	SEMI-DOUBLE SEAT ASSY	1	UR YAMAHA BLACK FOR FWB
	3TB-24770-60	SEMI-DOUBLE SEAT ASSY	1	UR VIVID MAGENTA
	3TB-24770-00	SEMI-DOUBLE SEAT ASSY	1	SOLID 2 FOR PWS 1 UR RADICAL GRAY FOR YB
2	3TB-24731-40	.COVER, seat	1	UR YAMAHA BLACK FOR FWB
	3TB-24731-60	.COVER, seat	1	UR VIVID MAGENTA
	3TB-24731-00	.COVER, seat	1	SOLID 2 FOR PWS 1 UR RADICAL GRAY FOR YB
3	3TB-24723-00	.DAMPER, seat	1	
4	3TB-24185-00	.DAMPER, locating 5	1	
5	90119-06063	BOLT, with washer	2	
6	26H-21308-00	HELMET HANGER ASSY	1	
7	90149-06154	SCREW	1	



3TB351-1250

D11

FIG. 26 FRONT WHEEL

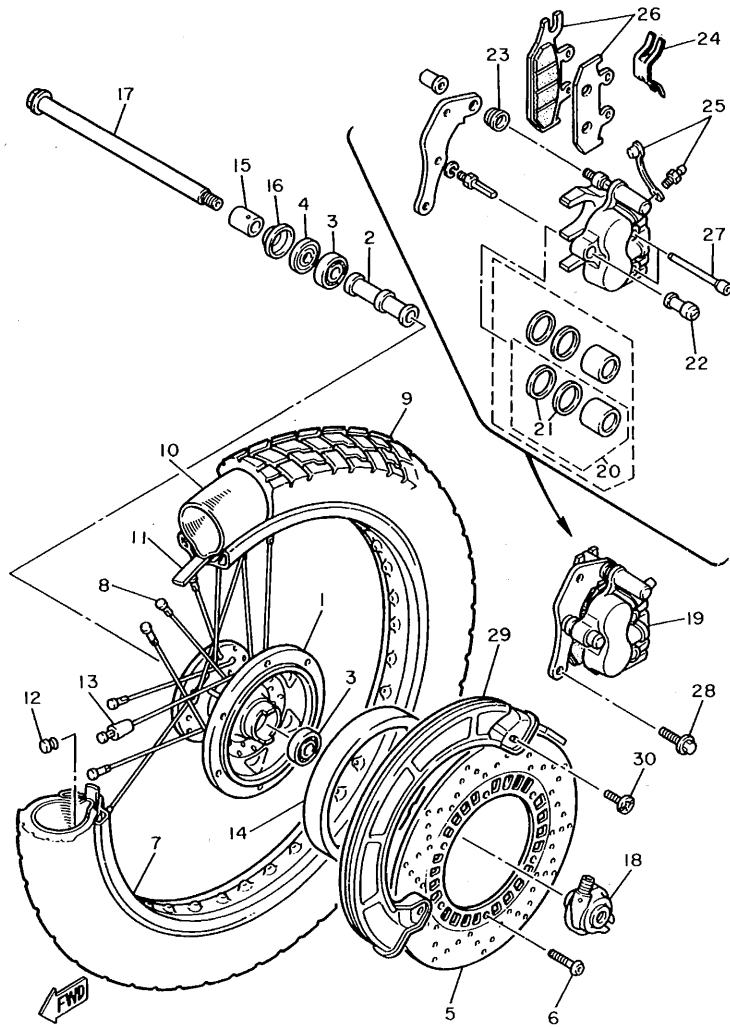

3TB351-0260

REF. NO.	PART NO.	DESCRIPTION	Q'TY	REMARKS
1	3TB-25111-00-98	HUB, front	1	LOW GLOSS BLACK
2	90560-15240	SPACER	1	
3	93306-20209	BEARING (B6202)	2	
4	93102-20281	OIL SEAL (SD 20-35-5)	1	
5	3TB-2582T-00	DISC, brake	1	
6	90149-06251	SCREW	6	
7	94418-21492	RIM (1.85-21)	1	
8	3TB-25104-00	SPOKE SET, front	1	
9	94109-213X0	TIRE (MCS 90/90-21 54S TW41)	1	UR BRIDGESTONE
	94109-213X1	TIRE (90/90-21 54S TRAILMAX)	1	UR DUNLOP
10	94209-21277	TUBE (MCS 90/90-21 TR-4)	1	BRIDGESTONE
11	94330-21084	BAND, rim (3.00-21)	1	BRIDGESTONE
12	90338-09130	PLUG	1	
13	156-25398-00	BALANCER, wheel	1	UN
14	3TB-25336-00	RING 2	1	
15	90387-152J3	COLLAR	1	
16	322-25118-00	COVER, hub dust	1	
17	55U-25181-01	AXLE, wheel	1	
18	34L-25190-01	GEAR UNIT ASSY	1	
19	3TB-2580T-00	CALIPER ASSY (LEFT)	1	
20	3TB-W0057-00	.PISTON ASSY, caliper	2	
21	3GD-W0047-00	..CALIPER SEAL KIT	2	
22	1UY-25937-51	.BOOT 2	1	
23	3JD-25917-00	.BOOT, caliper	1	
24	3TB-25919-00	.SUPPORT, pad	1	
25	1UY-W0048-50	.BREED SCREW KIT	1	
26	3TB-W0045-00	.BRAKE PAD KIT	1	
27	3TB-25933-00	.PIN, pad	2	

FIG. 26 FRONT WHEEL

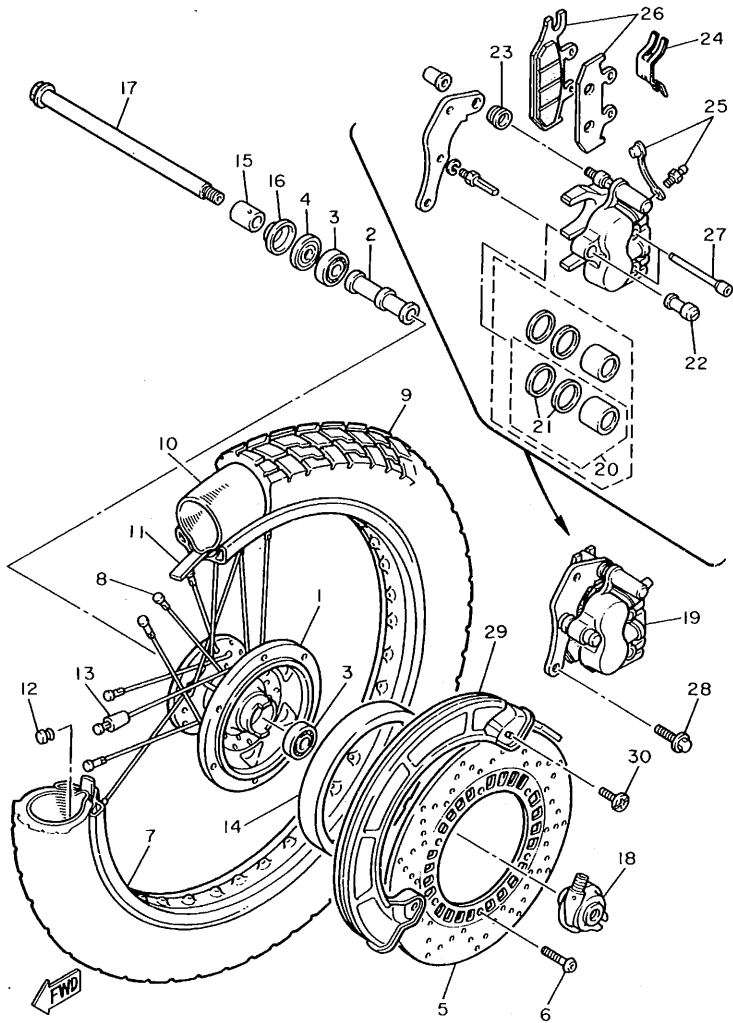

3TB351-0260

REF. NO.	PART NO.	DESCRIPTION	Q'TY	REMARKS
28	90105-10316	BOLT, washer based	2	
29	3TB-25715-20	COVER 1	1	UR PURPLISH WHITE
	55W-25715-10	COVER 1	1	SOLID 1 FOR PWS 1
	55W-25715-00	COVER 1	1	UR INK BLUE
				FOR FWB
				UR BLACK FOR YB
30	90149-06194	SCREW	2	

D13

FIG. 27 REAR WHEEL

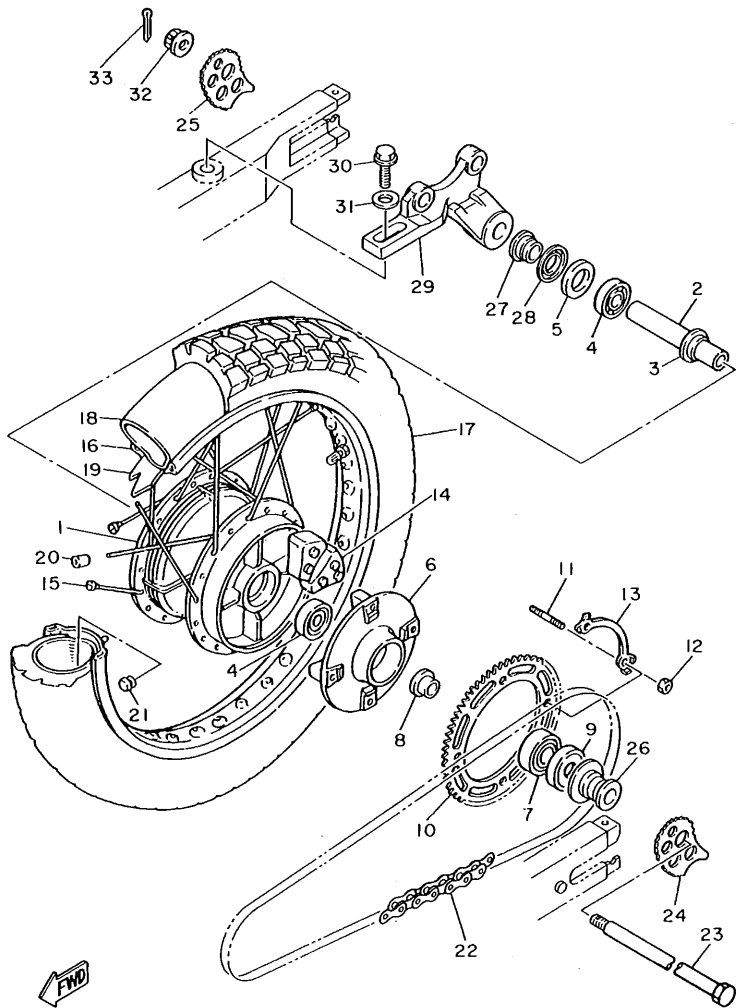

3T8351-0270

REF. NO.	PART NO.	DESCRIPTION	Q'TY	REMARKS
1	2KF-25311-00-98	HUB, rear	1	LOW GLOSS BLACK
2	90387-173M5	COLLAR	1	
3	146-25315-00	FLANGE, spacer	1	
4	93306-20310	BEARING (B6203DU)	2	
5	93102-25311	OIL SEAL (FPJ 25-44-8 TS)	1	
6	1VJ-25366-01-98	CLUTCH, hub	1	LOW GLOSS BLACK
7	93306-30416	BEARING (B6304RS)	1	
8	1VJ-25377-00	COLLAR, wheel	1	
9	93102-30072	OIL SEAL (SD-30-52-8-1)	1	
10	2UJ-25445-50	SPROCKET, driven (45T)	1	
11	90116-10348	BOLT, stud	4	
12	90170-10219	NUT	4	
13	5Y1-25412-00	WASHER	2	
14	5Y1-25364-00	DAMPER	4	
15	3TB-25304-00	SPOKE SET, rear	1	
16	94425-17491	RIM (2.50-17)	1	
17	94112-173X2	TIRE (MCS 120/90-17 64S TW42B)	1	UR BRIDGESTONE
	94112-173X3	TIRE (120/90-17 64S TRAILMAX)	1	UR DUNLOP
18	94212-17264	TUBE (MCS 120/90-17 TR-4)	1	UR BRIDGESTONE
	94212-17281	TUBE (120/90.130/80-17)	1	UR DUNLOP
19	94330-17158	BAND, rim (3.00-17)	1	BRIDGESTONE
20	156-25398-00	BALANCER, wheel	1	UN
21	90338-09130	PLUG	1	
22	94581-45106	CHAIN (DID520V2-106LE)	1	
23	3AJ-25381-00	AXLE, wheel	1	
24	3Y1-25388-01	PULLER, chain 1	1	
25	3Y1-25389-00	PULLER, chain 2	1	
26	1VJ-25383-00	COLLAR, wheel	1	

FIG. 27 REAR WHEEL

REF. NO.	PART NO.	DESCRIPTION	Q'TY	REMARKS
27	90387-174F0	COLLAR	1	
28	36R-25367-00	COVER, hub dust	1	
29	2KF-25819-00	BRACKET, caliper	1	
30	95811-10030	BOLT, flange	1	
31	90201-10437	WASHER, plate	1	
32	90171-16024	NUT, castle	1	
33	91401-30030	PIN, cotter	1	

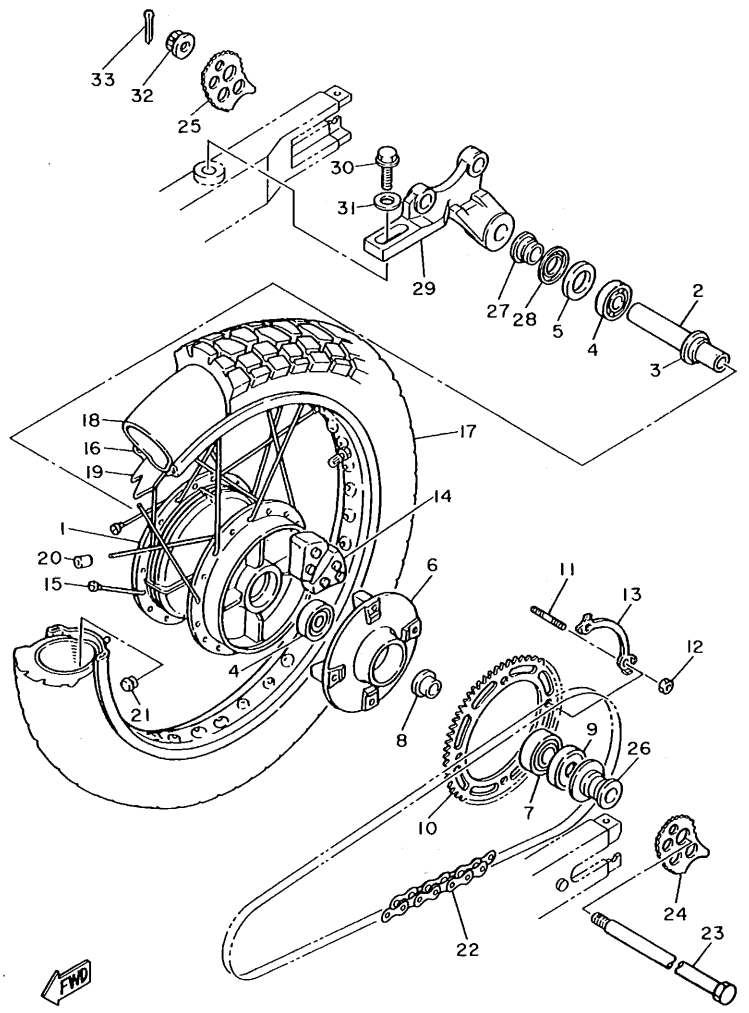

FWD
3TB351-0270

D15

FIG. 28 REAR BRAKE CALIPER

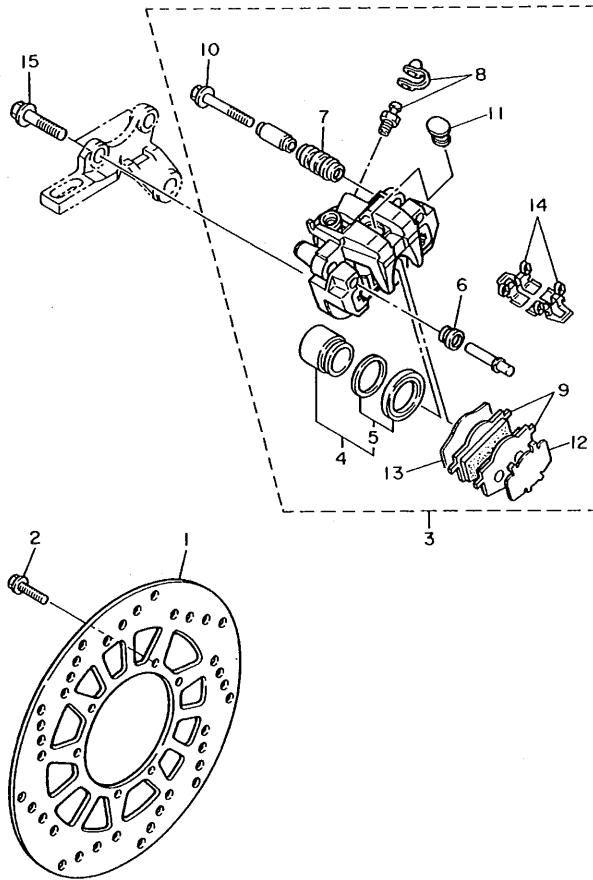

REF. NO.	PART NO.	DESCRIPTION	Q'TY	REMARKS
1	2KF-25831-50	DISC, brake	1	
2	90109-06757	BOLT	6	
3	3TB-2580W-00	CALIPER ASSY, rear 2	1	
4	2KF-W0057-00	.PISTON ASSY, caliper	1	
5	34X-W0047-00	..CALIPER SEAL KIT	1	
6	5R2-25937-00	.BOOT 2	1	
7	34X-25937-00	.BOOT 2	1	
8	51L-W0048-00	.BREED SCREW KIT	1	
9	34X-W0046-02	.BRAKE PAD KIT, 2	1	
10	2GV-25926-00	.BOLT	1	
11	34X-25845-00	.CAP, indicator	1	
12	2KF-25827-00	.SHIM, caliper	1	
13	2KF-25828-00	.SHIM, caliper	1	
14	2KF-25919-10	.SUPPORT, pad	2	
15	90105-10308	BOLT, washer based	2	



3TB351-0280

E2

FIG. 29 STEERING HANDLE • CABLE

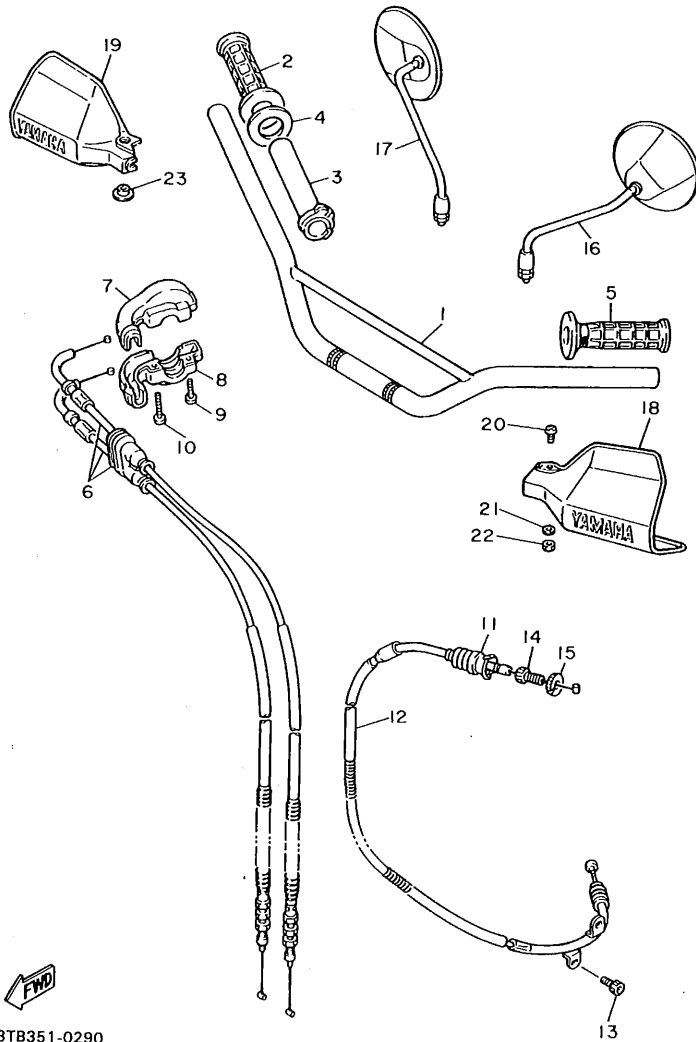

3TB351-0290

REF. NO.	PART NO.	DESCRIPTION	Q'TY	REMARKS
1	3TB-26111-01	HANDLEBAR	1	
2	33G-26242-00	GRIP (RIGHT)	1	
3	3Y1-26243-01	TUBE, throttle guide	1	
4	3Y1-26249-00	RING, leaf	1	
5	33G-26241-00	GRIP (LEFT)	1	
6	3TB-26302-00	THROTTLE CABLE ASSY	1	
7	34K-26281-00	CAP, grip upper	1	
8	1VJ-26282-00	CAP, grip lower	1	
9	98506-05020	SCREW, pan head	1	
10	98506-05025	SCREW, pan head	1	
11	1E6-26342-00	BOOT, cable	1	
12	3TB-26335-00	CABLE, clutch	1	
13	91316-06010	BOLT	1	
14	90123-08046	BOLT	1	
15	90179-08148	NUT	1	
16	55V-26280-00	REAR VIEW MIRROR ASSY (LEFT)	1	UR FOR EUROPE
	1Y1-26290-50	REAR VIEW MIRROR ASSY (LEFT)	1	UR FOR OCEANIA
17	55V-26290-00	REAR VIEW MIRROR ASSY (RIGHT)	1	UR FOR EUROPE
	1Y1-26290-60	REAR VIEW MIRROR ASSY (RIGHT)	1	UR FOR OCEANIA
18	1VJ-26141-00	GUARD, brush 1	1	UR FARAWAY BLUE
	3BN-26141-20	GUARD, brush 1	1	UR PURPLISH WHITE SOLID 1 FOR PWS 1
	2KF-26141-00	GUARD, brush 1	1	UR YAMAHA BLACK FOR YB
19	3TB-26142-40	GUARD, brush 2	1	UR FARAWAY BLUE
	3TB-26142-60	GUARD, brush 2	1	UR PURPLISH WHITE SOLID 1 FOR PWS 1
	3TB-26142-70	GUARD, brush 2	1	UR YAMAHA BLACK FOR YB
20	98501-06035	SCREW, pan head	1	
21	92901-06600	WASHER, plate	1	
22	95303-06700	NUT	1	
23	90387-06500	COLLAR	1	

E3

FIG. 30 FRONT MASTER CYLINDER

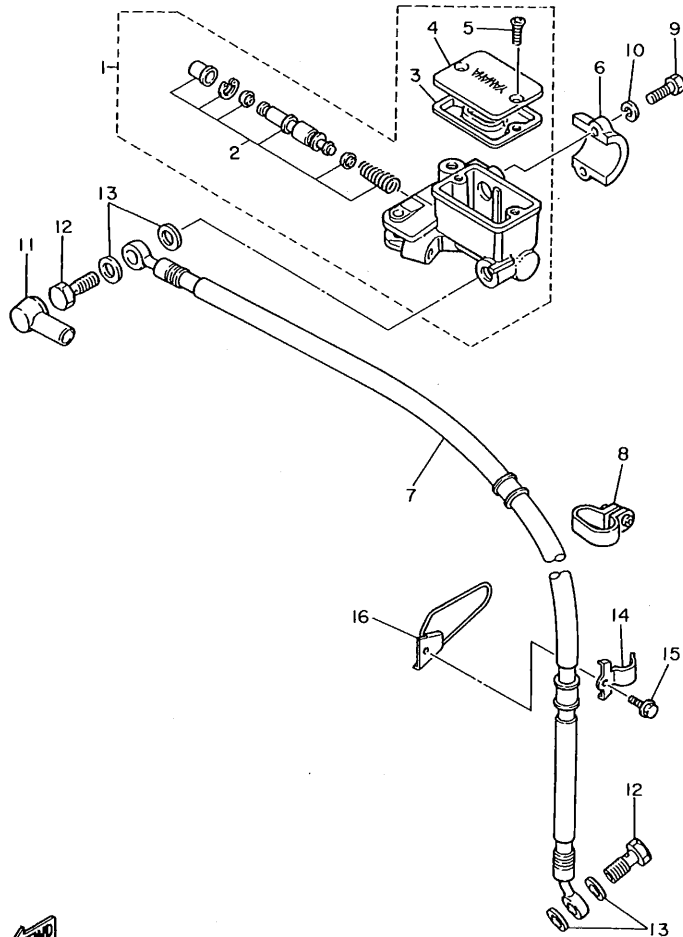

REF. NO.	PART NO.	DESCRIPTION	Q'TY	REMARKS
1	3TB-25870-00	MASTER CYLINDER SUB ASSY	1	
2	3TB-W0041-00	.CYLINDER KIT, master	1	
3	4L0-25854-00	.DIAPHRAGM, reservoir	1	
4	4H7-25852-00	.CAP, reservoir	1	
5	98706-04012	.SCREW, flat head	2	
6	4L0-25867-00	BRACKET, master cylinder	1	
7	3TB-25872-01	HOSE, brake 1	1	
8	99999-02107	CLAMP	1	
9	97016-06025	BOLT	2	
10	92906-06100	WASHER, spring	2	
11	4L0-25862-00	BOOT, master cylinder	1	
12	90401-10034	BOLT, union	2	
13	90201-10118	WASHER, plate	4	
14	90461-16124	CLAMP	1	
15	91001-06016	BOLT, flange	1	
16	3TB-23318-00	HOLDER, cable 1	1	



3TB351-1300

FIG. 31 STAND • FOOTREST

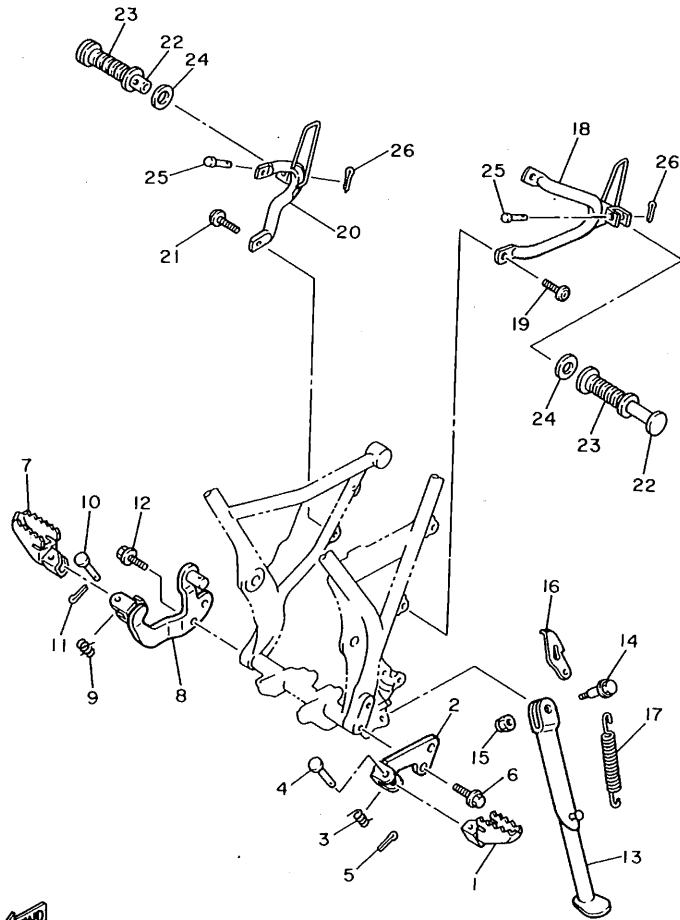

REF. NO.	PART NO.	DESCRIPTION	Q'TY	REMARKS
1	22W-27411-01-90	FOOTREST 1	1	*UNI-CHROME (BLACK CHROMATE) BLACK (FOR ELECTRODEPOSIT)
2	34L-27412-00-R4	BRACKET, footrest 1	1	
3	90508-20023	SPRING, torsion	1	
4	91701-08038	PIN, clevis	1	
5	91401-25020	PIN, cotter	1	
6	95826-10025	BOLT, flange	2	
7	22W-27421-01-90	FOOTREST 2	1	*UNI-CHROME (BLACK CHROMATE) BLACK (FOR ELECTRODEPOSIT)
8	2KF-27422-00-R4	BRACKET, footrest 2	1	
9	90508-20023	SPRING, torsion	1	
10	91701-08038	PIN, clevis	1	
11	91401-25020	PIN, cotter	1	
12	95826-10025	BOLT, flange	2	
13	3AJ-27311-00-R4	STAND, side	1	BLACK (FOR ELECTRODEPOSIT)
14	90105-12616	BOLT, washer based	1	
15	90185-12119	NUT, self-locking	1	
16	5Y1-27315-00	LINK, side stand	1	
17	90507-32020	SPRING, tension	1	
18	26F-27432-00-WL	BRACKET 1	1	STARDUST SILVER
19	95816-08016	BOLT, flange	2	
20	3YP-27442-00-WL	BRACKET 2	1	STARDUST SILVER
21	95816-08016	BOLT, flange	2	
22	120-27431-00	FOOTREST, rear 1	2	
23	120-27433-00	COVER, rear footrest	2	
24	90201-20279	WASHER, plate	2	
25	90240-06009	PIN, clevis	2	
26	91401-16015	PIN, cotter	2	



3TB351-1310

E5

FIG. 32 REAR MASTER CYLINDER

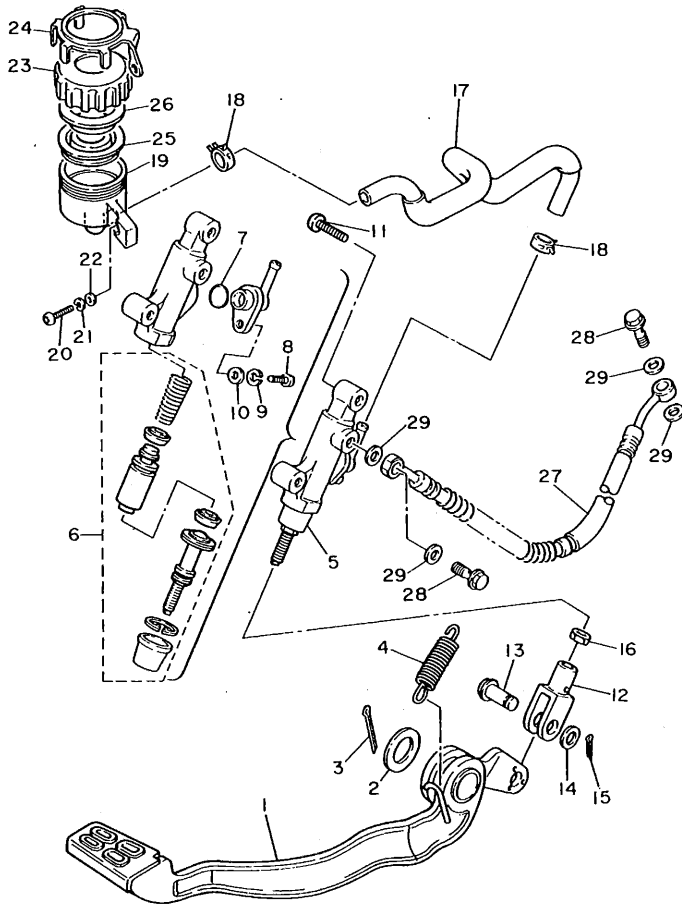

3TB351-0320

REF. NO.	PART NO.	DESCRIPTION	Q'TY	REMARKS
1	3TB-27211-00-90	PEDAL, brake	1	*UNI-CHROME (BLACK CHROMATE)
2	90201-14215	WASHER, plate	1	
3	91401-30020	PIN, cotter	1	
4	90507-18055	SPRING, tension	1	
5	3TB-2583V-00	RR. MASTER CYLINDER ASSY.	1	
6	31A-W0042-50	.CYLINDER KIT, master	1	
7	93210-15620	.O-RING	1	
8	98511-04012	.SCREW, pan head	1	
9	92902-04100	.WASHER, spring	1	
10	92901-04600	.WASHER, plate	1	
11	92016-08025	SCREW	2	
12	47X-27222-00	JOINT	1	
13	90240-08013	PIN, clevis	1	
14	90201-08083	WASHER, plate	1	
15	91401-16015	PIN, cotter	1	
16	95303-08700	NUT	1	
17	3TB-25895-00	HOSE, reservoir	1	
18	90467-14057	CLIP	2	
19	47X-25894-00	TANK, reservoir	1	
20	98501-06020	SCREW, pan head	1	
21	92990-06100	WASHER, spring	1	
22	92901-06600	WASHER, plate	1	
23	2KF-25852-50	CAP, reservoir	1	
24	3AJ-25888-00	COVER, reservoir tank	1	
25	360-25854-00	DIAPHRAGM, reservoir	1	
26	2GU-25855-00	BUSH, diaphragm	1	
27	3TB-25873-01	HOSE, brake 2	1	
28	90401-10034	BOLT, union	2	

FIG. 32 REAR MASTER CYLINDER

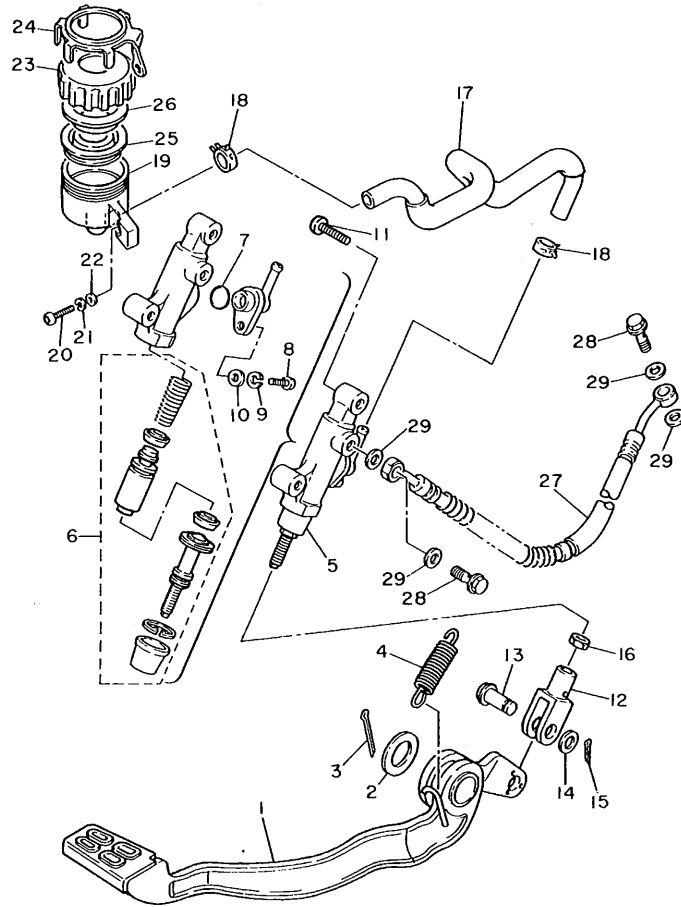

REF. NO.	PART NO.	DESCRIPTION	Q'TY	REMARKS
29	90201-10118	WASHER, plate	4	



3TB351-0320

E7

FIG. 33 COWLING 1

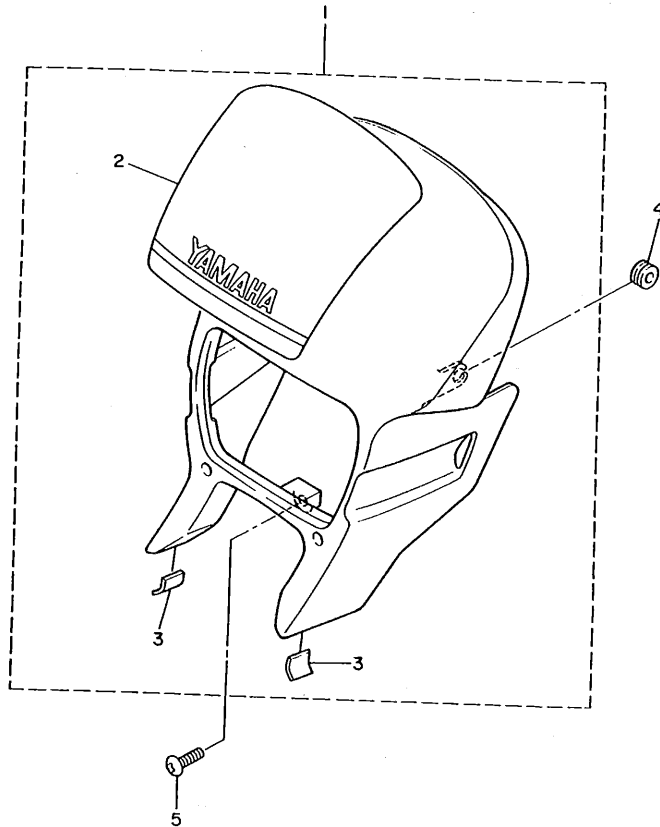

REF. NO.	PART NO.	DESCRIPTION	Q'TY	REMARKS
1	3TB-W2834-60	BODY, cowling	1	UR FARAWAY BLUE FOR FWB
	3TB-W2834-70	BODY, cowling	1	UR PURPLISH WHITE SOLID 1 FOR PWS 1
	3TB-W2834-80	BODY, cowling	1	UR YAMAHA BLACK FOR YB
2	3TB-28368-61	.GRAPHIC 1	1	UR FOR FWB
	3TB-28368-71	.GRAPHIC 1	1	UR FOR PWS 1
	3TB-28368-81	.GRAPHIC 1	1	UR FOR YB
3	3TB-28217-00	.DAMPER 1	2	
4	90480-12053	GROMMET	2	
5	90149-06263	SCREW	1	



3UY110-2330

FIG. 34 GENERATOR

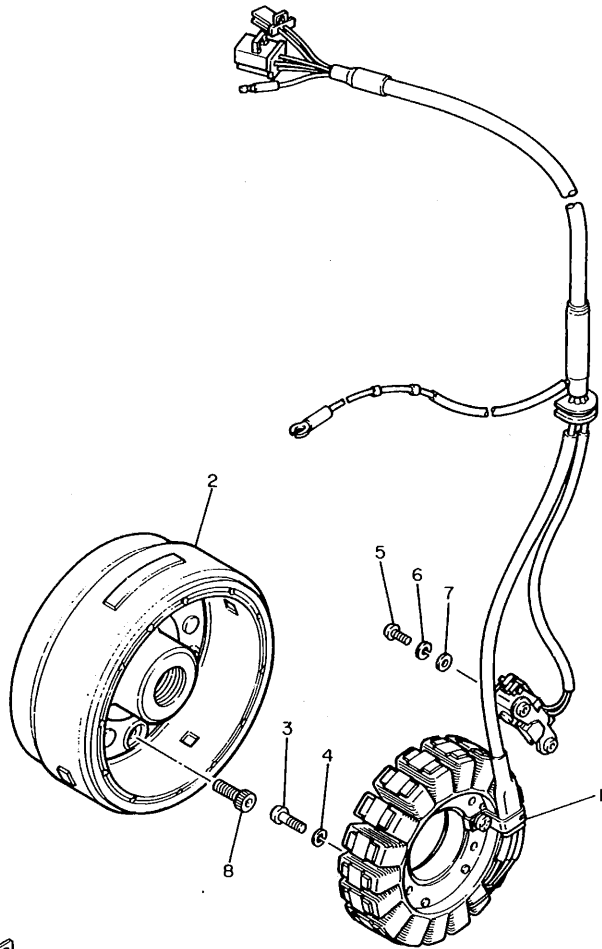

REF. NO.	PART NO.	DESCRIPTION	Q'TY	REMARKS
1	3TB-81410-00	STATOR ASSY	1	
2	3TB-81450-00	ROTOR ASSY	1	
3	98501-06025	SCREW, pan head	3	
4	92990-06100	WASHER, spring	3	
5	98501-05016	SCREW, pan head	2	
6	92901-05100	WASHER, spring	2	
7	92901-05600	WASHER, plate	2	
8	90110-08193	BOLT, hexagon socket head	3	



3TB351-0340

E9

FIG. 35 FLASHER LIGHT

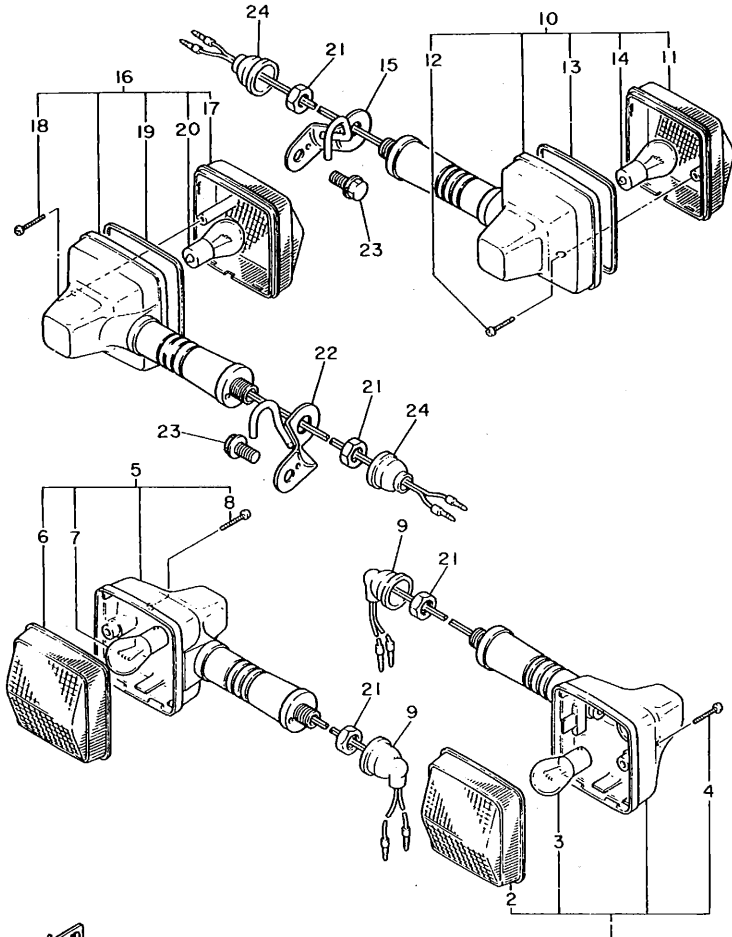

3TB351-0350

REF. NO.	PART NO.	DESCRIPTION	Q'TY	REMARKS
1	3TB-83310-00	FRONT FLASHER LIGHT ASSY 1	1	
2	47J-83312-00	.LENS, flasher	1	
3	306-83311-40	.BULB, flasher (12V-21W)	1	
4	97706-40620	.SCREW, tapping	2	
5	3TB-83320-00	FRONT FLASHER LIGHT ASSY 2	1	
6	47J-83322-00	.LENS, flasher 2	1	
7	306-83311-40	.BULB, flasher (12V-21W)	1	
8	97706-40620	.SCREW, tapping	2	
9	18G-83365-00	CAP	2	
10	3CK-83330-00	REAR FLASHER LIGHT ASSY 1	1	
11	2KF-83332-00	.LENS, flasher	1	
12	97706-40620	.SCREW, tapping	1	
13	47J-83313-00	.GASKET, flasher lens	1	
14	306-83311-40	.BULB, flasher (12V-21W)	1	
15	3TB-83368-00	STAY, flasher 1	1	
16	3CK-83340-00	REAR FLASHER LIGHT ASSY 2	1	
17	2KF-83342-00	.LENS, flasher 2	1	
18	97706-40620	.SCREW, tapping	1	
19	47J-83313-00	.GASKET, flasher lens	1	
20	306-83311-40	.BULB, flasher (12V-21W)	1	
21	95311-12700	NUT	4	
22	3TB-83369-00	STAY, flasher 2	1	
23	95806-08014	BOLT, flange	2	
24	10V-83365-00	CAP	2	

FIG. 36 METER

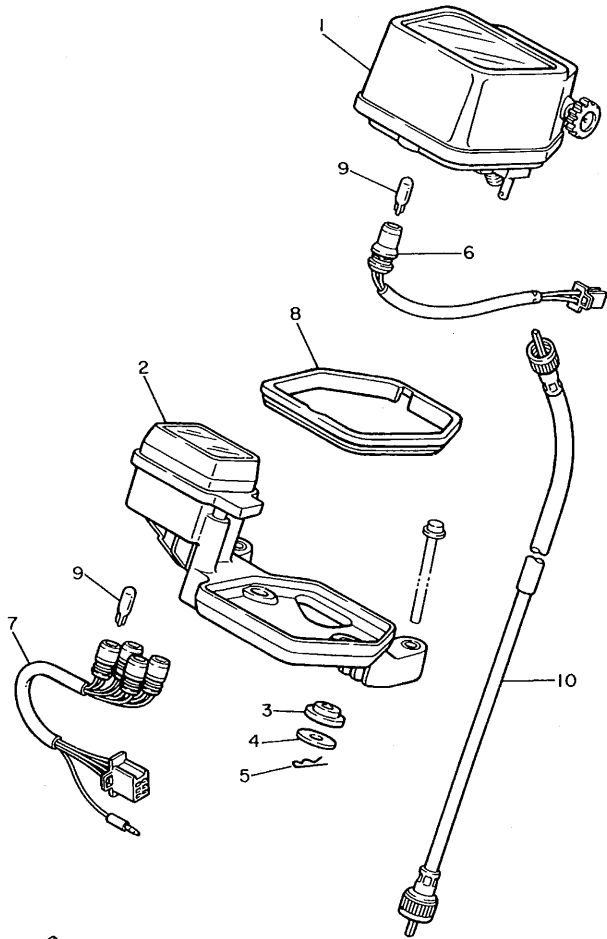

REF. NO.	PART NO.	DESCRIPTION	Q'TY	REMARKS
1	3TB-83570-00	SPEEDOMETER ASSY	1	KPH
2	3TB-8355A-10	BRACKET, meter	1	
3	1M1-83526-00	DAMPER 2	2	
4	90201-05033	WASHER, plate	2	
5	90468-10050	CLIP	2	
6	3TB-83536-00	SOCKET, meter	1	
7	3TB-83520-00	SOCKET CORD ASSY	1	
8	5Y1-83513-00	DAMPER	1	
9	4G1-84744-00	BULB (12V-3.4W)	5	
10	3ET-83550-01	SPEEDOMETER CABLE ASSY	1	



3TB351-0360

E11

FIG. 37 HEADLIGHT

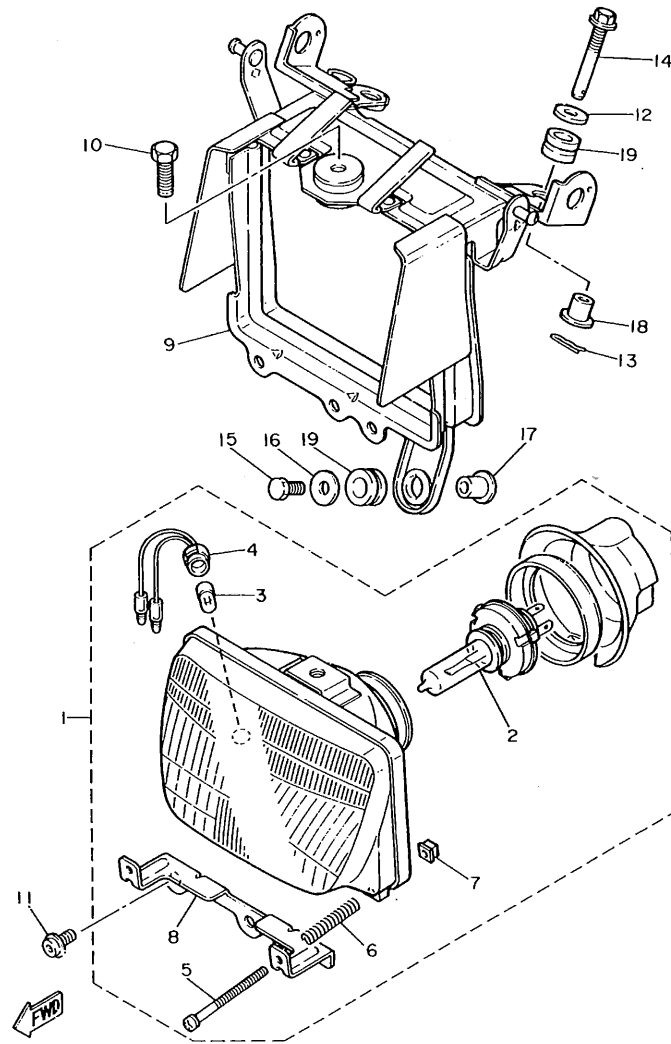

3TB332-0370

REF. NO.	PART NO.	DESCRIPTION	Q'TY	REMARKS
1	3TB-84320-10	LENS ASSY	1	
2	2F9-84314-00	.BULB, headlight (12V 60/55W)	1	HALOGEN
3	4E2-84347-00	.BULB (12V-4W)	1	
4	3TB-84312-00	.SOCKET	1	
5	3TB-84325-00	.SCREW, rim fitting	2	
6	341-84332-60	.SPRING, screw	2	
7	198-84334-60	.NUT, adjusting	2	
8	3TB-8431R-00	.STAY, setting	1	
9	3TB-84311-00	BODY, headlight	1	
10	3TB-84372-01	BOLT, lamp stay	1	
11	3TB-84329-00	BOLT, wing 1	2	
12	90202-06013	WASHER, plate	2	
13	90468-12120	CLIP	2	
14	3TB-84137-00	BOLT, special	2	
15	97016-06025	BOLT	1	
16	90201-06059	WASHER, plate	1	
17	90387-06388	COLLAR	1	
18	90387-07391	COLLAR	2	
19	90480-14023	GROMMET	3	

FIG. 38 TAILLIGHT

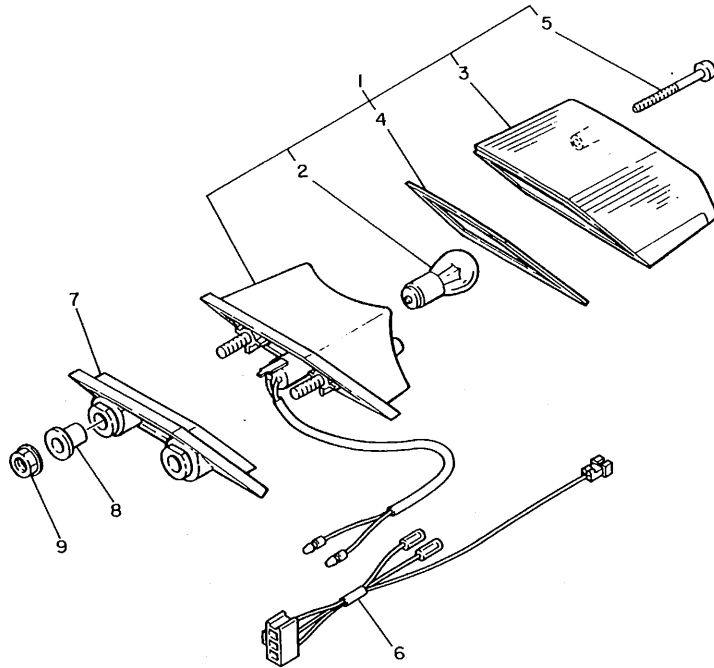

REF. NO.	PART NO.	DESCRIPTION	Q'TY	REMARKS
1	1XL-84710-E0	TAILLIGHT UNIT ASSY	1	
2	31L-84714-00	.BULB, taillight (12V-21/5W)	1	
3	53V-84721-40	.LENS, taillight	1	
4	34Y-84723-E0	.GASKET, tail lens	1	
5	97706-40530	.SCREW, tapping	2	
6	3TB-84717-00	CORD, taillight	1	
7	34X-84527-00	DAMPER	1	
8	90387-07391	COLLAR	2	
9	95701-06500	NUT, flange	2	



3TB351-0380

E13

FIG. 39 HANDLE SWITCH • LEVER

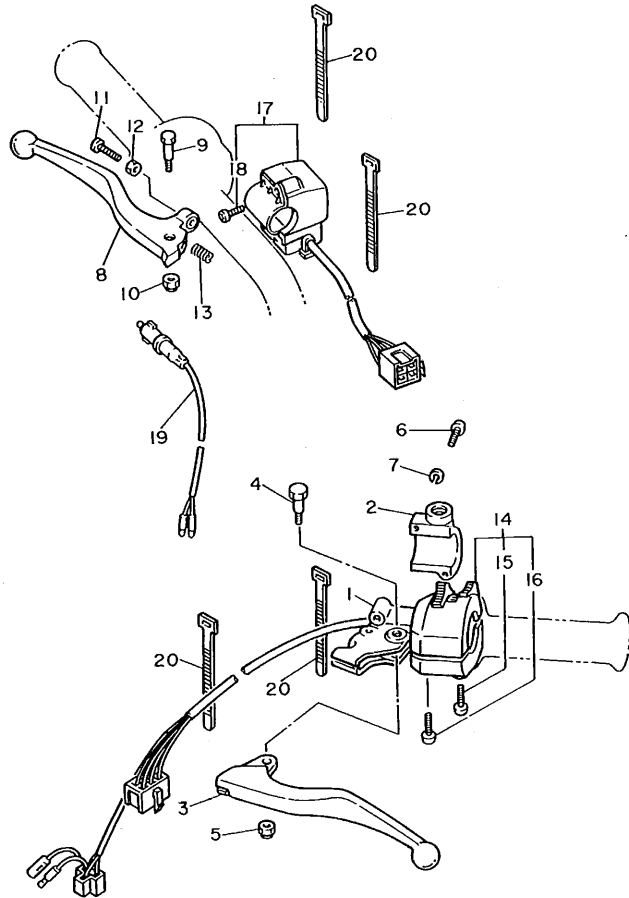

REF. NO.	PART NO.	DESCRIPTION	Q'TY	REMARKS
1	1LN-82911-00	HOLDER, lever 1	1	
2	33G-82913-00	HOLDER, lever lower 1	1	
3	3FY-83912-01	LEVER 1	1	
4	90109-06799	BOLT	1	
5	95616-06100	NUT, u	1	
6	98506-05020	SCREW, pan head	2	
7	92906-05100	WASHER, spring	2	
8	3YR-83922-00	LEVER 2	1	
9	90109-062A8	BOLT	1	
10	95616-06100	NUT, u	1	
11	90149-06153	SCREW	1	
12	90170-06010	NUT	1	
13	90501-10312	SPRING, compression	1	
14	3TB-83972-00	SWITCH, handle 4	1	
15	98506-05030	SCREW, pan head	1	
16	98506-05035	SCREW, pan head	1	
17	3TB-83975-00	SWITCH, handle 2	1	
18	98506-05012	SCREW, pan head	1	
19	34X-83980-01	FRONT STOP SWITCH ASSY	1	
20	437-83936-01	BAND, switch cord	4	



3TB351-0390

FIG. 40 ELECTRICAL 1

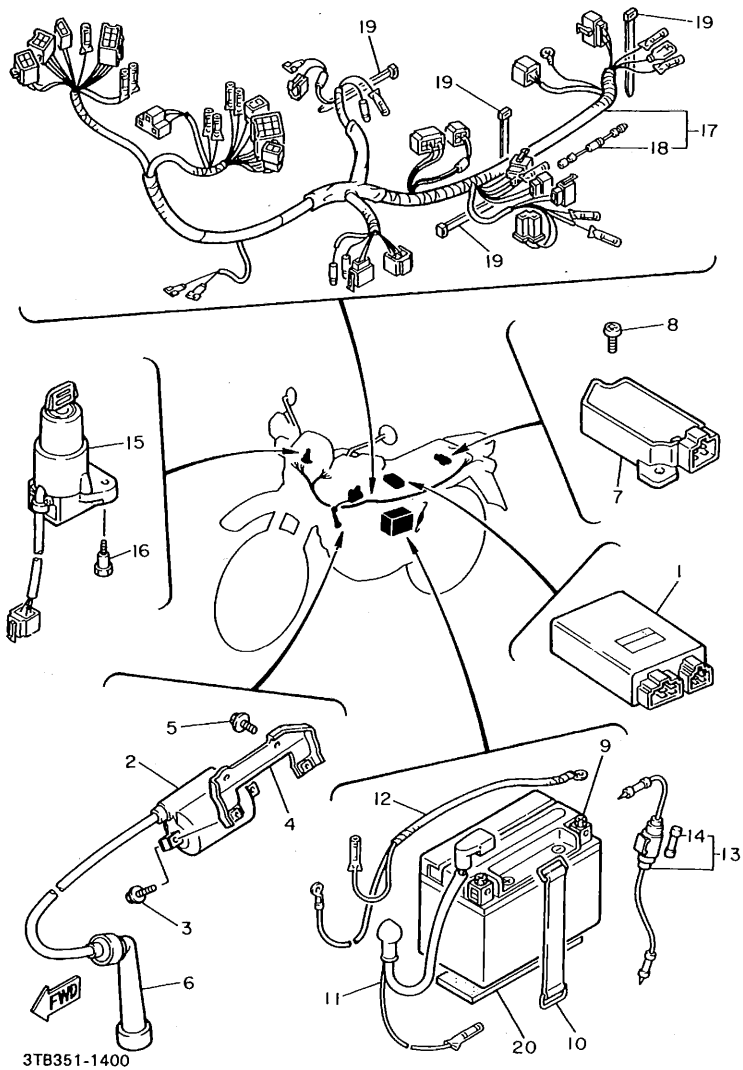

REF. NO.	PART NO.	DESCRIPTION	Q'TY	REMARKS
1	3TB-82305-00	IGNITOR UNIT ASSY	1	
2	3SX-82310-00	IGNITION COIL ASSY	1	
3	97021-05020	BOLT	2	
4	3TB-82316-00	BRACKET, ignition coil	1	
5	95811-06010	BOLT, flange	2	
6	371-82370-00	PLUG CAP ASSY	1	
7	47X-81960-A2	RECTIFIER & REGULATOR ASSY	1	
8	98501-06012	SCREW, pan head	2	
9	3PK-82100-00	BATTERY ASSY (YTX9-BS 12V-8AH)	1	
10	120-82131-00	BAND, battery	1	
11	3TB-82115-00	WIRE, plus lead	1	
12	3TB-82116-00	WIRE, minus lead	1	
13	2UJ-82150-01	FUSE HOLDER ASSY	1	
14	148-82151-00	.FUSE (20A)	1	
15	3TB-82501-10	MAIN SWITCH STEERING LOCK	1	
16	90109-06614	BOLT	2	
17	3TB-82590-01	WIRE HARNESS ASSY	1	
18	3K7-81980-00	.RECTIFIER 2	1	
19	12R-82591-00	BAND	4	
20	5X2-24183-00	DAMPER, locating 3	1	

3TB351-1400

FIG. 41 ELECTRICAL 2

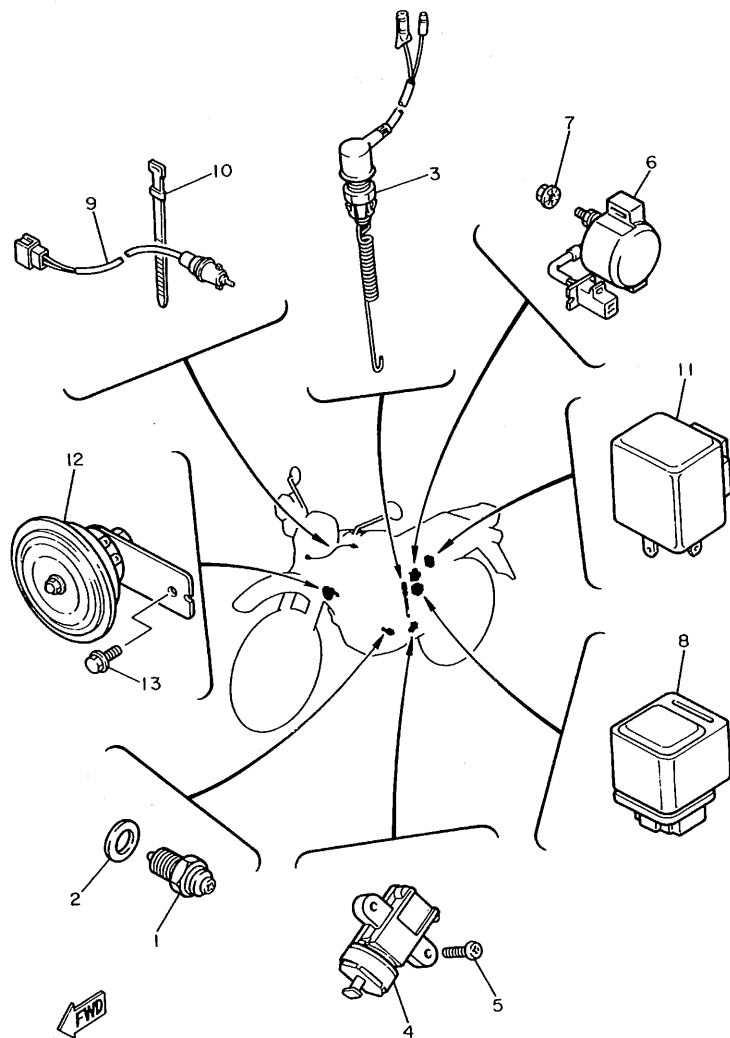

3TB351-0410

REF. NO.	PART NO.	DESCRIPTION	Q'TY	REMARKS
1	2H7-82540-00	NEUTRAL SWITCH ASSY	1	
2	90430-10171	GASKET	1	
3	34L-82530-02	STOP SWITCH ASSY	1	
4	3LD-82566-00	SWITCH, side stand	1	
5	98506-05016	SCREW, pan head	2	
6	3AY-81940-00	STARTER RELAY ASSY	1	
7	95701-06500	NUT, flange	2	
8	12R-81950-01	RELAY ASSY	1	
9	2GV-82917-00	SWITCH	1	
10	25G-83936-01	BAND, switch cord	1	
11	34L-83350-20	FLASHER RELAY ASSY	1	
12	3TB-83371-00	HORN	1	
13	95026-06010	BOLT, flange	1	



INDIVIDUAL SPEC.



**FOR DENMARK
FINLAND
NORWAY
SWEDEN**

The following pages provides a listing of only the parts that meet the specifications peculiar to your market. For those parts not appearing in these pages, refer to the "GENERAL SPEC" section.

FIG. 42 ALTERNATE (FENDER)

REF. NO.	PART NO.	DESCRIPTION	Q'TY	REMARKS
1	3RW-21511-40	FENDER, front	*	FARAWAY BLUE
2	3TB-21511-40	FENDER, front	1	UR FARAWAY BLUE
3	3RW-21511-60	FENDER, front	*	PURPLISH WHITE SOLID 1
4	3TB-21511-60	FENDER, front	1	UR PURPLISH WHITE SOLID 1
5	3RW-21511-70	FENDER, front	*	YAMAHA BLACK
6	3TB-21511-70	FENDER, front	1	UR YAMAHA BLACK
7	3TB-21521-00	FLAP, front fender	1	
8	90267-32071	RIVET, blind	3	
9	92990-03200	WASHER, plain	6	
10	2KF-21685-01	BRACKET, license	*	
11	2KF-21685-11	BRACKET, license	1	
12	1VJ-21621-00	FLAP	1	
13	98506-04018	SCREW, pan head	4	
14	92906-04200	WASHER, plain	4	
15	95606-04100	NUT, u	4	
16	33G-85132-00	BRACKET, reflector 1	*	
17	90201-044A2	WASHER, plate	*	
18	90267-40090	RIVET, blind	*	

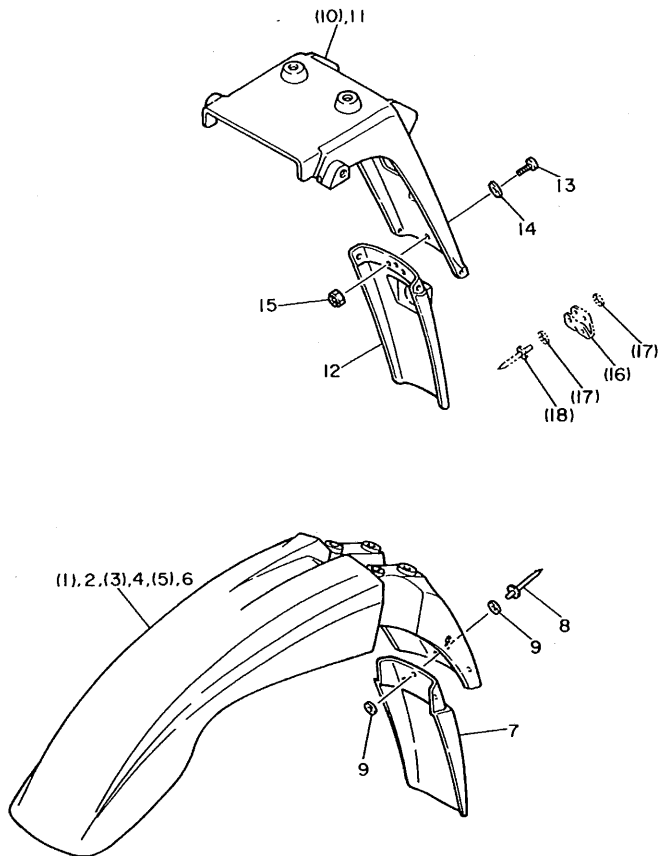



3TB300-0430

F4

FOR ENGLAND OCEANIA

The following pages provides a listing of only the parts that meet the specifications peculiar to your market. For those parts not appearing in these pages, refer to the "GENERAL SPEC" section.

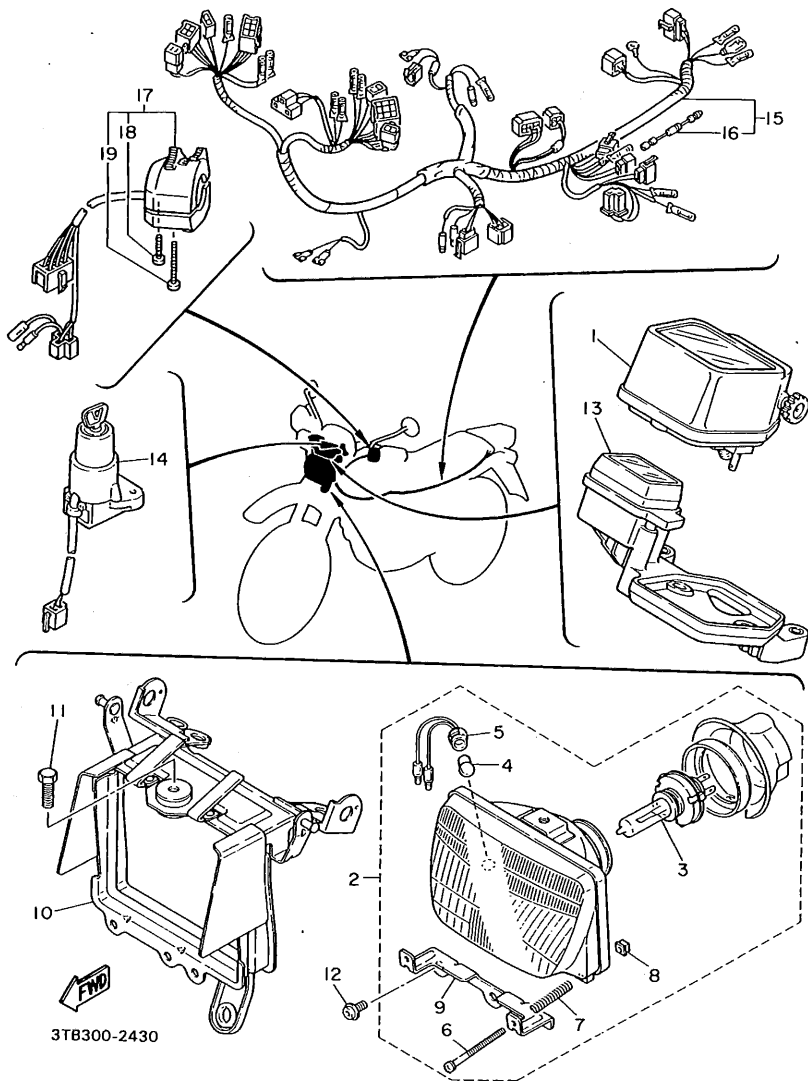
FIG. 43 ALTERNATE (ELECTRICAL)



REF. NO.	PART NO.	DESCRIPTION	Q'TY	REMARKS
1	3TB-83570-00	SPEEDOMETER ASSY	1	UR KPH
	3TB-83570-20	SPEEDOMETER ASSY	1	UR MPH
2	3TB-84320-20	LENS ASSY	1	UR FOR ENGLAND
	3WR-84320-00	LENS ASSY	1	UR FOR OCEANIA
3	2F9-84314-00	.BULB (12V-60/55W)	1	HALOGEN
4	123-83516-21	.BULB (12V-3.4W)	1	
	4E2-84347-00	.BULB (12V-4W)	1	
5	3TB-84312-00	.SOCKET	1	
6	3TB-84325-00	.SCREW, rim fitting	2	
7	341-84332-60	.SPRING, screw	2	
8	198-84334-60	.NUT, adjusting	2	
9	3TB-8431R-00	.STAY, setting	1	
10	3TB-84311-00	BODY, headlight	1	
11	3TB-84372-01	BOLT, lamp stay	1	
12	3TB-84329-00	BOLT, wing 1	2	
13	3TB-8355A-00	METER BRACKET	1	
14	4DW-82501-00	MAIN SWITCH	1	
15	3WR-82590-00	WIRE HARNESS ASSY	1	
16	3K7-81980-00	.RECTIFIER 2	1	} FOR OCEANIA ONLY
17	3UY-83973-00	SWITCH, handle 4	1	
18	98500-05022	.SCREW, pan head	1	
19	98506-05033	.SCREW, pan head	1	

FOR SWITZERLAND

The following pages provides a listing of only the parts that meet the specifications peculiar to your market. For those parts not appearing in these pages, refer to the "GENERAL SPEC" section.

FIG. 44 ALTERNATE (ENGINE)

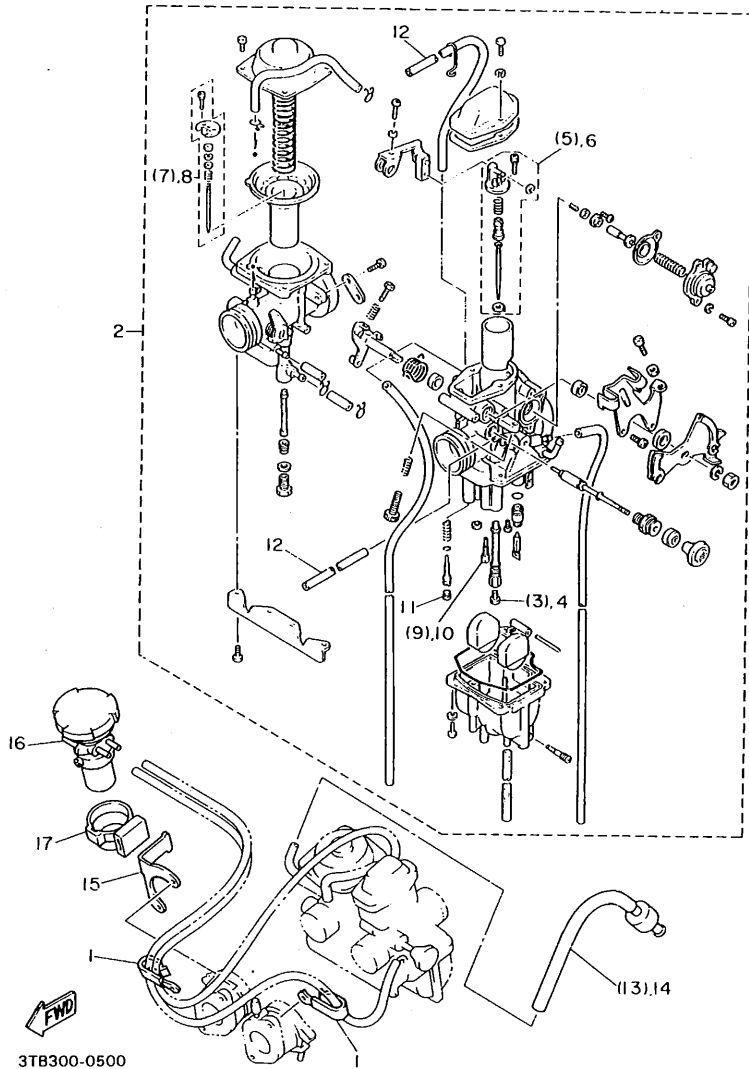

REF. NO.	PART NO.	DESCRIPTION	Q'TY	REMARKS
1	90465-08125	CLAMP	2	
2	3UX-14301-00	CARBURETOR ASSY	1	
3	288-14343-65	.JET, main (# 130)	*	
4	288-14343-63	.JET, main (# 125)	1	
5	3TB-1490J-10	.NEEDLE SET	*	
6	3UX-1490J-10	.NEEDLE SET	1	
7	3TB-1490J-00	.NEEDLE SET	*	
8	2KF-1490J-00	.NEEDLE SET	1	
9	43F-14342-25	.JET, pilot (# 50)	*	
10	43F-14342-23	.JET, pilot (# 46)	1	
11	2WJ-14367-00	.PLUG	1	
12	2WJ-14349-00	.PIPE	2	
13	3TB-14197-00	PIPE, air ven	*	
14	3LD-14197-00	PIPE, air vent	1	
15	3UX-1441L-01	BRACKET, 1	1	
16	3UX-14303-00	COMPENSATOR	1	
17	2WJ-14445-01	GROMMET	1	

As for the remaining parts not listed here, Refer to the carburetor section (Fig. 8) on Grid No. of B13 and B14.

FIG. 45 ALTERNATE (CHASSIS)

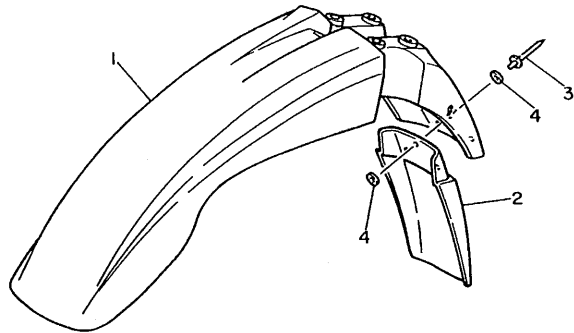
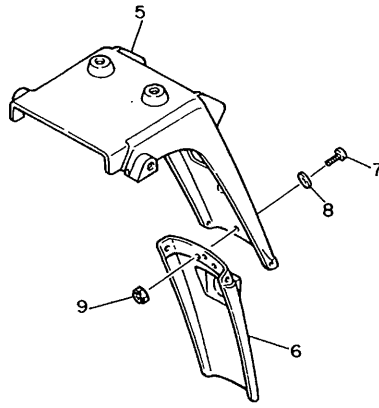

REF. NO.	PART NO.	DESCRIPTION	Q'TY	REMARKS
1	3TB-21511-40	FENDER, front	1	UR FARAWAY BLUE
	3TB-21511-60	FENDER, front	1	UR PURPLISH WHITE SOLID 1
	3TB-21511-70	FENDER, front	1	UR YAMAHA BLACK
2	3TB-21521-00	FLAP	1	
3	90267-32071	RIVET, blind	3	
4	92901-03200	WASHER, plain	6	
5	2KF-21685-11	BRACKET, license	1	
6	1VJ-21621-00	FLAP	1	
7	98506-04016	SCREW, pan head	4	
8	92906-04200	WASHER, plain	4	
9	95606-04100	NUT, u	4	



3TB300-0510



INDEX
(GENERAL SPEC.)

NUMERICAL INDEX

PART NO.	REF NO.	PART NO.	REF NO.
3TB-W0041-00	E - 4	2F3-12117-00	B - 7
31A-W0042-50	E - 6	1J7-12118-00	B - 7
3TB-W0045-00	D-12	1J7-12119-01	B - 7
34X-W0046-02	E - 2	1VJ-12121-00	B - 7
3GD-W0047-00	D-12	2NX-12146-00	B - 7
34X-W0047-00	E - 2	34K-12151-00	B - 7
1UY-W0048-50	D-12	2NX-12156-00	B - 7
51L-W0048-00	E - 2	2NX-12159-00	B - 7
2KF-W0057-00	E - 2	34K-12161-00	B - 7
3TB-W0057-00	D-12	34K-12162-00	B - 7
1VJ-W1141-00	B - 5	34K-12163-00	B - 7
5Y1-W1343-00	B - 9	2NX-12166-00	B - 7
3TB-W2147-00-WL	C-12	1JK-12171-00	B - 8
3TB-W2341-00	D - 6	3TB-122176-00	B - 8
3TB-W2834-60	E - 8	3TB-12210-00	B - 8
3TB-W2834-70	E - 8	4DW-12213-00	B - 8
3TB-W2834-80	E - 8	3TB-12215-00	B - 2
3TB-11101-00	B - 2	34K-12231-00	B - 8
583-11127-00	B - 2	34K-12241-00	B - 8
	B - 4	583-13113-00	B - 9
4H7-11133-10	B - 2	3AJ-13161-00	B - 9
34K-11145-00	B - 6	3AJ-13300-01	B - 9
3TB-11166-00	C - 2	3AJ-13325-00	B - 9
2KF-11181-01	B - 4	3SX-13329-00	B - 9
1L9-11186-00	B - 2	4DW-13415-00	B - 9
5Y1-11187-00	B - 2	4X7-13440-90	B - 9
214-11198-01	B - 9	2WK-13447-00	B - 9
3TB-11310-00	B - 4	3TB-13464-00	B - 9
1VJ-11351-00	B - 4	3TB-13465-00	B -10
3TB-11400-00	B - 5	16G-13569-00	B -11
34K-11454-00	B - 5	43F-13586-01	B -11
5Y1-11496-01	B - 5	1VJ-13596-00	B -11
5Y1-11531-00	B - 5	2KF-1410A-00	B -14
2JT-11536-00	B - 5	2NX-14103-00	B -14
34K-11565-02	B - 5	51Y-14105-00	B -14
34L-11610-00	B - 5	2JN-14107-00	B -14
34L-11610-20	B - 5	1XL-14131-00	B -13
34L-11610-40	B - 5	30X-14148-00	B -14
3TB-11631-00-YO	B - 5	5Y1-14149-00	B -14
1JK-11633-01	B - 5	5Y1-14159-00	B -14
3TB-11636-00	B - 5	7KF-14162-00	B -14
3TB-11638-00	B - 5	1JK-14197-00	B -13
3TB-11651-00	B - 5	1VJ-14197-00	B -13
1VJ-11681-00	B - 5	3TD-14197-00	B -14
1VJ-12111-00	B - 7	5Y1-14198-00	B -13
5Y1-12113-00	B - 7	7KF-14227-00	B -13
5Y1-12114-00	B - 7	1VJ-14286-00	B -13
4H7-12116-00	B - 7	1JK-14291-00	B -13

NUMERICAL INDEX

PART NO.	REF NO.	PART NO.	REF NO.
3DS-15100-00	C - 2	3Y6-15144-00	C - 2
3Y6-15144-00	C - 2	3Y6-15167-00	C - 2
3Y6-15167-00	C - 2	5Y1-15383-00	C - 2
5Y1-15383-00	C - 2	3TB-15411-01	C - 3
3TB-15411-01	C - 3	3TB-15415-00	C - 4
3TB-15415-00	C - 4	2WK-15418-01	C - 3
2WK-15418-01	C - 3	3AJ-15421-00	C - 3
3AJ-15421-00	C - 3	5Y1-15427-01	B - 9
5Y1-15427-01	B - 9	3DS-15430-00	C - 3
3DS-15430-00	C - 3	1JK-15449-00	C - 3
1JK-15449-00	C - 3	4DW-15451-00	C - 3
4DW-15451-00	C - 3	4DW-15455-00	C - 4
4DW-15455-00	C - 4	4DW-15462-00	C - 3
4DW-15462-00	C - 3	1JK-15486-00	C - 3
1JK-15486-00	C - 3	1VJ-15511-00	C - 5
1VJ-15511-00	C - 5	1VJ-15512-00	C - 5
1VJ-15512-00	C - 5	3TB-15515-00	C - 5
3TB-15515-00	C - 5	1VJ-15517-00	C - 5
1VJ-15517-00	C - 5	1VJ-15521-00	C - 5
1VJ-15521-00	C - 5	3TB-15590-00	C - 5
3TB-15590-00	C - 5	3TB-15594-00	C - 5
3TB-15594-00	C - 5	3AJ-16111-00	C - 6
3AJ-16111-00	C - 6	3AJ-16150-00	C - 6
3AJ-16150-00	C - 6	2JN-16154-00	C - 6
2JN-16154-00	C - 6	5Y1-16321-00	C - 6
5Y1-16321-00	C - 6	360-16325-00	C - 6
360-16325-00	C - 6	5Y1-16331-01	C - 6
5Y1-16331-01	C - 6	5Y1-16351-00	C - 6
5Y1-16351-00	C - 6	34K-16356-00	C - 6
34K-16356-00	C - 6	5Y1-16357-00	C - 7
5Y1-16357-00	C - 7	30X-16358-00	C - 6
30X-16358-00	C - 6	2JN-16371-00	C - 6
2JN-16371-00	C - 6	1VJ-16380-01	C - 6
1VJ-16380-01	C - 6	5Y1-16383-00	B -15
5Y1-16383-00	B -15	34K-17121-01	C - 8
34K-17121-01	C - 8	1VJ-17131-00	B -15
1VJ-17131-00	B -15	34K-17141-00	B -15
34K-17141-00	B -15	2JT-17151-01	C - 8
2JT-17151-01	C - 8	3AJ-17221-00	C - 8
3AJ-17221-00	C - 8	1VJ-17231-00	C - 8
1VJ-17231-00	C - 8	3AJ-17241-00	C - 8
3AJ-17241-00	C - 8	2JT-17251-00	C - 8
2JT-17251-00	C - 8	2RW-17402-00	C - 8
2RW-17402-00	C - 8	2RW-17411-00	C - 8
2RW-17411-00	C - 8	5Y1-17471-00	C - 8
5Y1-17471-00	C - 8		

PART NO.	REF NO.	PART NO.	REF NO.
5Y1-18101-02	C -11	3TB-21721-60	D - 2
43F-18102-02	C -11	3TB-21721-70	D - 2
1VJ-18110-01	C -11	3TB-2173L-60	D - 2
1W6-18113-00	C -11	3TB-2173L-70	D - 2
34K-18120-00	C -11	3TB-2173L-80	D - 2
34K-18140-00	C -10	3TB-2174L-60	D - 2
5Y1-18511-00	C -10	3TB-2174L-70	D - 2
5Y1-18512-00	C -10	3TB-2174L-80	D - 2
5Y1-18513-00	C -10	3TB-2174A-00	D - 2
34K-18531-00	C -10	3TB-2174A-10	D - 2
34K-18535-00	C -10	3TB-2174T-00	C -14
3YF-18540-00	C -10	3TB-21750-00	C -12
136-18542-00	C -10	3TB-2177F-00	D - 2
3YP-21110-00-WL	C -12	3TB-21771-00	C -13
26H-21308-00	D -11	3TB-22110-00	D - 3
34L-21315-00	C -12	34L-22117-00	D - 4
3TB-21316-00-WL	C -12	1VJ-22123-00	D - 3
3TB-21338-00	C -13	2K6-22128-01	D - 3
3TB-2137W-00	D - 9	34L-22128-00	D - 3
3TB-2137W-40	D - 9	23X-22129-00	D - 4
3TB-2137W-60	D - 9	34L-22129-00	D - 5
3TB-2137X-00	D -10	1VJ-22141-00	D - 4
2KF-2137X-40	D -10	2KF-22147-00	D - 3
3TB-2137X-60	D -10	5X6-22151-10	D - 3
3TB-2137Y-00	D -10	3TB-2217A-00	D - 3
46X-21376-00	D - 2	34L-2217F-00	D - 3
5Y1-21441-00	C -12	3TB-22178-00	C -12
34K-21485-00	C -12	30X-22178-00	C -13
34K-21486-00	C -12	4V4-22184-00	C -12
3RW-21511-40	C -14		C -13
3RW-21511-60	C -14	3TB-22189-00	D - 4
3RW-21511-70	C -14	38V-22199-00	D - 3
3TB-21542-00	D - 2	3TB-22210-00-33	D - 5
3TB-21611-40	C -14	34L-22216-00	D - 5
3TB-21611-60	C -14	34L-22226-01	D - 5
3TB-21611-70	C -14	3TB-22311-00	D - 4
3TB-21621-00	B -12	3TB-23102-00	D - 7
3TB-2163A-00	C -14	3TB-23103-00	D - 7
3TB-21639-00	C -14	3TB-23110-00	D - 7
42U-21639-00	C -14		D - 8
3TB-2164F-00	C -15	3EN-23111-50	D - 7
3TB-21651-00	C -14		D - 8
2KF-21685-01	C -14	3FW-23118-00	D - 7
34X-21691-00	B -12		D - 8
3TB-21711-40	D - 2	4H7-23119-00	D - 7
3TB-21711-60	D - 2	3LC-23125-00	D - 7
3TB-21711-70	D - 2	3TB-23126-00	D - 7
3TB-21721-40	D - 2	2KF-23127-01	D - 8

NUMERICAL INDEX

PART NO.	REF NO.	PART NO.	REF NO.
122-23129-00	D-7	3TB-24232-60	D-10
3TB-23136-00	D-7	3TB-24232-70	D-10
3TB-23141-00	D-7	3TB-24232-80	D-10
	D-8	3TB-24240-60	D-9
43F-23142-10	D-7	3TB-24240-70	D-9
	D-8	3TB-24240-80	D-9
43F-23144-10	D-7	3FY-24500-00	D-9
43F-23145-10	D-7	360-24512-00	B-13
36Y-23146-10	D-7	4X8-24512-00	D-9
26H-23156-00	D-7	3AJ-24523-00	D-9
4V4-23158-L0	D-7	3AJ-24534-00	D-9
	D-8	11H-24602-02	D-9
4V2-23167-L0	D-8	3TB-24723-00	D-11
3TB-23170-00	D-7	23T-24724-01	D-9
	D-8	3TB-24731-00	D-11
3GM-23173-00	D-7	3TB-24731-40	D-11
	D-8	3TB-24731-60	D-11
4V4-23181-L0	D-7	3TB-24770-00	D-11
	D-8	3TB-24770-60	D-11
43F-23188-10	D-7	3TB-25104-00	D-12
	D-8	3TB-25111-00-98	D-12
3BJ-23191-01	D-8	322-25118-00	D-12
3BN-23191-21	D-8	55U-25181-01	D-12
43M-23192-L0	D-8	34L-25190-01	D-14
3TB-2331E-00	D-6	3TB-25304-00	D-14
3TB-23318-00	E-4	2KF-25311-00-98	D-14
34L-23318-01	D-6	146-25315-00	D-14
3TB-23340-00	D-8	3TB-25336-00	D-12
1W1-23416-00	D-6	5Y1-25364-00	D-14
5A8-23434-00	D-6	1VJ-25366-01-98	D-14
1E6-23441-00	D-6	36R-25367-00	D-15
3Y6-23442-00-98	D-6	1VJ-25377-00	D-14
3TB-24110-00-X1	D-9	3AJ-25381-00	D-14
3TB-24110-00-08	D-9	1VJ-25383-00	D-14
3TB-24110-00-09	D-9	3Y1-25388-01	D-14
3TB-2416F-00	D-10	3Y1-25389-00	D-14
3TB-2416F-10	D-10	156-25398-00	D-14
3TB-2416G-00	D-10		D-14
22W-24181-00	B-15		D-14
3TB-24181-00	D-9	5Y1-25412-00	D-14
43F-24182-00	D-9	2UJ-25445-50	D-14
5X2-24183-00	E-15	3TB-25715-20	D-13
3TB-24185-00	D-11	55W-25715-10	D-13
3TB-24186-00	D-9	55W-25715-00	D-13
3TB-24188-00	D-9	3TB-2580T-00	D-12
3TB-24231-60	D-9	3TB-2580W-00	E-2
3TB-24231-80	D-9	2KF-25819-00	D-15
3TB-24231-70	D-10	3TB-2582T-00	D-12

PART NO.	REF NO.	PART NO.	REF NO.
2KF-25827-00	E-2	2KF-25828-00	E-2
3TB-2583V-00	E-6	2KF-25831-50	E-2
	E-2	34X-25845-00	D-9
	E-6	2KF-25852-50	D-9
	E-4	4H7-25852-00	D-9
	E-6	360-25854-00	B-13
	E-4	4L0-25854-00	D-9
	E-6	2GU-25855-00	D-9
	E-4	4L0-25862-00	D-9
	E-4	4L0-25867-00	D-9
	E-4	3TB-25870-00	D-11
	E-4	3TB-25872-01	D-9
	E-6	3TB-25873-01	D-11
	E-6	3AJ-25888-00	D-11
	E-6	47X-25894-00	D-11
	E-6	3TB-25895-00	D-11
	D-12	3JD-25917-00	D-12
	E-2	2KF-25919-10	D-11
	D-12	3TB-25919-00	D-12
	E-2	2GV-25926-00	D-12
	D-12	3TB-25933-00	D-12
	D-12	1UY-25937-51	D-12
	E-2	34X-25937-00	D-12
	E-2	5R2-25937-00	D-14
	E-3	3TB-26111-01	D-14
	E-3	1LN-26141-00	D-14
	E-3	2KF-26141-00	D-12
	E-3	3BN-26141-20	D-14
	E-3	3TB-26142-40	D-14
	E-3	3TB-26142-60	D-15
	E-3	3TB-26142-70	D-14
	E-3	33G-26241-00	D-14
	E-3	33G-26242-00	D-14
	E-3	3Y1-26243-01	D-14
	E-3	3Y1-26249-00	D-14
	E-3	55V-26280-00	D-12
	E-3	34K-26281-00	D-14
	E-3	1VJ-26282-00	D-14
	E-3	1Y1-26290-60	D-14
	E-3	1Y1-26290-50	D-13
	E-3	55V-26290-00	D-13
	E-3	3TB-26302-00	D-13
	E-3	3TB-26335-00	D-12
	E-3	1E6-26342-00	E-2
	E-6	3TB-27211-00-90	D-15
	E-6	47X-27222-00	D-12

PART NO.	REF NO.	PART NO.	REF NO.
3AJ-27311-00-R4	E-5	5Y1-27315-00	E-5
22W-27411-01-90	E-5	34L-27412-00-R4	E-5
	E-5	22W-27421-01-90	E-5
	E-5	2KF-27422-00-R4	E-5
	E-5	120-27431-00	E-4
	E-5	26F-27432-00-WL	E-5
	E-5	120-27433-00	E-5
	E-5	3YP-27442-00-WL	E-5
	D-4	2KF-27491-00	D-4
	E-4	3TB-28100-00	E-4
	E-8	3TB-28217-00	E-8
	E-8	3TB-28368-61	E-8
	E-8	3TB-28368-71	E-8
	E-8	3TB-28368-81	E-8
	C-13	3TB-28415-00	C-13
	E-9	3TB-81410-00	E-9
	E-9	3TB-81450-00	E-9
	C-5	3TB-81800-00	C-5
	C-5	3AJ-81801-00	C-5
	C-5	3AJ-81809-00	C-5
	C-5	3AJ-81820-00	C-5
	C-5	3AJ-81830-00	C-5
	C-5	11H-81844-00	C-5
	C-5	26H-81847-00	C-5
	C-5	3AJ-81850-00	C-5
	C-5	4G0-81871-00	C-5
	F-2	3AY-81940-00	F-2
	B-11	12R-81950-01	B-11
	E-15	3TB-81953-00	E-15
	E-15	47X-81960-A1	E-15
	E-15	3K7-81980-00	E-15
	E-15	3PK-82100-00	E-15
	E-15	3TB-82115-00	E-15
	E-15	3TB-82116-00	E-15
	E-15	120-82131-00	E-15
	E-15	2UJ-82150-00	E-15
	E-15	148-82151-00	E-15
	E-15	3TB-82305-00	E-15
	E-15	3SX-82310-00	E-15
	E-15	3TB-82316-00	E-15
	E-15	371-82370-00	E-15
	E-15	3TB-82501-10	E-15
	F-2	34L-82530-02	F-2
	F-2	2H7-82540-00	F-2
	F-2	3LD-82566-00	F-2
	E-15	3TB-82590-00	E-15

NUMERICAL INDEX

PART NO.	REF NO.	PART NO.	REF NO.
12R-82591-00	E-15	31L-84714-00	E-13
1LN-82911-00	E-14	3TB-84717-00	E-13
33G-82913-00	E-14	53V-84721-40	E-13
2GV-82917-00	F-2	34Y-84723-E0	E-13
3TB-83310-00	E-10	4G1-84744-40	E-11
306-83311-40	E-10	3YF-84751-00	C-15
47J-83312-00	E-10	3G1-85130-01	C-15
47J-83313-00	E-10	33G-85132-00	C-14
3TB-83320-00	E-10	90101-12295	D-5
47J-83322-00	E-10	90105-07087	B-8
3CK-83330-00	E-10	90105-08505	B-4
2KF-83332-00	E-10	90105-10186	B-15
3CK-83340-00	E-10	90105-10232	B-15
2KF-83342-00	E-10	90105-10286	C-12
34L-83350-20	F-2	90105-10308	E-2
10V-83365-00	E-10	90105-10316	D-13
18G-83365-00	E-10	90105-12616	E-5
3TB-83368-00	E-10	90105-12668	D-3
3TB-83369-00	E-10	90105-14102	D-6
3TB-83371-00	F-2	90109-062A8	E-14
5Y1-83513-00	E-11	90109-063E8	B-7
3TB-83520-00	E-11	90109-063F9	B-2
1M1-83526-00	E-11	90109-06418	B-2
3TB-83536-00	E-11	90109-06419	B-9
3TB-8355A-10	E-11	90109-06614	E-15
3ET-83550-01	E-11	90109-06757	E-2
3TB-83570-00	E-11	90109-06799	E-14
3FY-83912-01	E-14	90109-085E2	B-15
3YR-83922-00	E-14	90109-08705	C-13
25G-83936-01	F-2	90109-10759	D-4
437-83936-01	E-14	90109-10760	D-4
3TB-83972-00	E-14	90110-06138	C-2
3TB-83975-00	E-14		C-3
34X-83980-01	E-14	90110-08193	E-9
3TB-84137-00	E-12	90116-06475	B-2
3TB-8431R-00	E-12	90116-10263	C-2
3TB-84311-00	E-12	90116-10348	D-14
3TB-84312-00	E-12	90116-10378	B-2
2F9-84314-00	E-12	90116-10506	C-2
3TB-84320-10	E-12	90119-06061	C-14
3TB-84325-00	E-12	90119-06063	D-11
3TB-84329-00	E-12	90119-06097	C-14
341-84332-60	E-12	90123-08046	E-3
198-84334-60	E-12	90149-05110	B-9
4E2-84347-00	F-2	90149-06153	E-14
3TB-84372-01	E-12	90149-06154	D-11
34X-84527-00	E-13	90149-06194	D-13
1XL-84710-E0	E-13	90149-06223	D-2

NUMERICAL INDEX

PART NO.	REF NO.	PART NO.	REF NO.	PART NO.	REF NO.
90149-06223	D-10	90201-10118	E-4	90338-30096	C-4
90149-06251	D-12		E-7	90340-08M04	C-3
90149-06263	E-8	90201-10124	B-4	90340-14068	B-2
90149-08067	C-6	90201-10144	B-15	90340-14132	B-9
90151-06017	C-10	90201-102J5	B-15	90340-36121	C-3
90159-06010	C-6	90201-10437	D-15	90380-14095	D-3
90159-06042	D-10	90201-10590	B-4	90380-14130	D-5
90159-06078	C-10	90201-120A5	D-3	90380-22111	D-3
90159-06084	D-4	90201-12474	C-11	90386-20120	D-3
90164-06017	B-15	90201-13409	C-13	90386-20123	D-4
90170-06010	E-14	90201-140A6	B-5	90387-06033	B-12
90170-06128	B-7	90201-140G9	D-3	90387-061V4	D-2
90170-10219	D-14	90201-14215	E-6	90387-062M3	C-14
90170-16343	B-6	90201-15238	D-4	90387-062V8	C-14
90170-20274	C-6	90201-17327	C-6	90387-063F7	C-10
90170-20327	C-6	90201-20276	C-8	90387-06388	E-12
90171-16024	D-15	90201-20279	E-5	90387-064J1	D-10
90176-08026	B-4	90201-244A8	D-3	90387-06500	E-3
90179-06499	B-15	90201-251F6	D-4	90387-066M3	C-14
90179-08148	E-3	90201-301F4	B-5	90387-06737	D-3
90179-10201	B-4	90201-303P4	C-5	90387-07391	C-12
90179-10279	B-4	90202-05193	D-9		E-12
90179-14317	B-5	90202-06013	E-12		E-12
90179-18552	C-8	90206-06090	B-15	90387-074X3	B-12
90179-25033	D-6	90206-12075	B-7	90387-07717	C-14
90185-10037	D-4	90209-05279	C-3	90387-085E1	C-13
90185-10060	C-12	90209-06223	D-3	90387-121H1	D-4
90185-10120	D-4	90209-22191	C-8	90387-122J6	D-4
90185-12119	E-5	90215-16242	B-6	90387-152J3	D-12
90185-14070	D-4	90215-20197	C-6	90387-16782	C-2
90201-04M06	C-12	90215-20231	C-6	90387-173M5	D-14
90201-044A2	C-14	90215-23265	C-8	90387-174F0	D-15
90201-047A2	B-12	90240-06009	E-5	90387-17783	C-2
90201-05033	E-11	90240-08013	E-6	90387-440G3	D-3
90201-06059	C-15	90240-14106	D-5	90401-08133	B-9
	E-12	90267-40075	B-11	90401-10034	E-4
90201-080L8	B-4		C-12		E-6
90201-08083	E-6	90267-40077	B-12	90430-05126	B-9
90201-08087	C-6	90267-40090	C-14	90430-06014	B-3
	C-12	90280-16053	B-5	90430-08143	C-3
90201-08326	B-15	90282-05013	B-6	90430-08178	B-4
90201-085L3	B-4	90282-07042	C-6		B-4
90201-08753	C-12	90336-18038	C-14	90430-08204	C-2
	C-13	90338-08174	B-12	90430-10171	B-9
90201-100A1	D-6	90338-09130	D-12	90430-22123	F-2
90201-100E9	D-4		D-14	90430-27124	C-12
90201-100F7	D-4	90338-21100	C-4	90445-10638	C-13
90201-101J1	B-15	90338-22207	B-3	90445-115G3	D-9
					C-13

NUMERICAL INDEX

PART NO.	REF NO.	PART NO.	REF NO.	PART NO.	REF NO.
90445-126G6	B-12	91311-06060	D-3	92902-04100	B-13
90450-22052	B-10	91316-06010	E-3		E-6
90460-46206	B-11	91316-06012	B-15	92906-05100	E-14
90460-51059	B-12	91316-06016	B-10	92906-05600	B-11
90460-58015	B-12		C-3	92906-06100	C-12
90461-12110	D-4	91316-06018	B-2		E-4
90461-16124	E-4	91316-06020	B-2	92906-06600	B-2
90462-15196	B-2		B-11	92990-04100	B-13
90462-16102	C-3	91316-06025	B-2	92990-04200	B-12
90465-08028	B-11		B-8	92990-06100	D-4
90465-08344	C-2		C-3		D-9
90467-09006	D-9		C-4		E-6
90467-10008	C-13	91316-06035	B-4		E-9
90467-10039	B-11		B-9	92990-14600	D-5
90467-11102	B-12		C-3	93101-14092	C-3
90467-12052	B-12		C-4	93101-25106	B-5
90467-14015	C-2	91316-06040	B-2	93102-12106	C-11
90467-14057	E-6	91316-06045	C-2	93102-17357	C-6
90467-17128	C-2	91316-06050	B-2	93102-20281	D-12
90468-10050	E-11		C-3	93102-25226	C-8
90468-12006	D-6	91316-06055	B-2	93102-25311	D-14
90468-12120	E-12	91316-06060	C-2	93102-30072	D-14
90480-01176	D-2	91316-06080	B-9	93106-22019	D-3
90480-01401	D-10	91316-06115	B-2	93108-35004	D-3
90480-12053	E-8	91316-06125	B-2	93210-07135	B-9
90480-12325	B-11	91401-16015	E-5		C-2
90480-13383	D-10		E-6	93210-08521	B-7
90480-14023	E-12	91401-25020	E-5	93210-10197	B-10
90480-14329	B-12	91401-30020	E-6	93210-13361	B-9
90480-15064	B-12	91401-30030	D-5		C-3
90480-15363	C-12		D-15	93210-13657	B-2
90501-043E0	B-9	91701-08038	E-5	93210-15171	B-10
90501-10312	E-14	91810-05018	B-4	93210-15620	E-6
90501-22721	B-5	92016-08025	E-6	93210-19522	B-2
90501-23142	C-6	92016-08050	C-15	93210-32172	B-2
90507-18055	E-6	92506-06012	C-12	93210-36510	C-3
90507-32020	E-5	92901-04600	B-11	93210-36549	B-11
90508-14710	C-6		E-6	93210-62446	B-2
90508-20023	E-5	92901-05100	E-9	93210-64297	B-9
90508-26691	C-10	92901-05600	D-6	93210-97524	B-4
90508-29629	C-11		E-9	93306-00426	C-8
90560-15240	D-12	92901-06200	C-6	93306-00431	C-8
90560-20199	C-9	92901-06600	B-8	93306-20006	C-5
90560-25283	C-8		D-3	93306-20209	D-12
91001-06016	E-4		E-3	93306-20310	D-14
91026-06010	C-13		E-6	93306-30416	D-14
91026-08040	D-6	92901-10100	C-12	93306-30525	B-5
91311-06025	C-14		D-6	93306-30535	C-8



INDEX
(INDIVIDUAL SPEC.)

NUMERICAL INDEX

PART NO.	REF NO.	PART NO.	REF NO.
3LD-14197-00	F - 8	92906-04200	F - 9
3UX-14301-00	F - 8	92990-03200	F - 4
3UX-14303-00	F - 8	95606-04100	F - 4
43F-14342-23	F - 8		F - 9
288-14343-63	F - 8	98506-04016	F - 9
2WJ-14349-00	F - 8	98506-04018	F - 4
2WJ-14367-00	F - 8	98506-05022	F - 6
3UX-1441L-01	F - 8	98506-05033	F - 6
2WJ-14445-01	F - 8		
2KF-1490J-00	F - 8		
3UX-1490J-10	F - 8		
3TB-21511-40	F - 4		
	F - 9		
3TB-21511-60	F - 4		
	F - 9		
3TB-21511-70	F - 4		
	F - 9		
3TB-21521-00	F - 4		
	F - 9		
1VJ-21621-00	F - 4		
	F - 9		
2KF-21685-11	F - 4		
	F-14		
3K7-81980-00	F - 6		
4DW-82501-00	F - 6		
3WR-82590-00	F - 6		
3UY-83973-00	F - 6		
123-83516-21	F - 7		
3TB-8355A-10	F - 6		
3TB-83570-00	F - 6		
3TB-83570-20	F - 6		
3TB-8431R-00	F - 6		
3TB-84311-00	F - 6		
3TB-84312-00	F - 6		
2F9-84314-00	F - 6		
3TB-84320-20	F - 6		
3WR-84320-00	F - 6		
3TB-84325-00	F - 6		
3TB-84329-00	F - 6		
341-84332-60	F - 6		
198-84334-60	F - 6		
4E2-84347-00	F - 6		
3TB-84372-01	F - 6		
90267-32071	F - 4		
	F - 9		
90465-08125	F - 8		
92901-03200	F - 9		
92906-04200	F - 4		

NUMERICAL INDEX

PART NO.	REF NO.	PART NO.	REF NO.
----------	---------	----------	---------



COPY RIGHT: ALL RIGHTS RESERVED
NO PART OF THIS PUBLICATION MAY BE
REPRODUCED WITHOUT PERMISSION.



PRINTED IN JAPAN
First edition Sep., 1991

